

## **Model-based engineering of an automotive Adaptive Exterior Lighting System**

Föcker, Felix; Houdek, Frank; Daun, Marian; Weyer, Thorsten

In: ICB Research Reports - Forschungsberichte des ICB / 2015

This text is provided by DuEPublico, the central repository of the University Duisburg-Essen.

This version of the e-publication may differ from a potential published print or online version.

DOI: <https://doi.org/10.17185/duepublico/47024>

URN: <urn:nbn:de:hbz:464-20180914-091208-1>

Link: <https://duepublico.uni-duisburg-essen.de/servlets/DocumentServlet?id=47024>

License:

As long as not stated otherwise within the content, all rights are reserved by the authors / publishers of the work. Usage only with permission, except applicable rules of german copyright law.

Source: ICB-Research Report No. 64, January 2015

Felix Föcker, Frank Houdek,  
Marian Daun, Thorsten Weyer



# Model-Based Engineering of an Automotive Adaptive Exterior Lighting System

**ICB-RESEARCH REPORT**

Realistic Example Specifications of  
Behavioral Requirements and  
Functional Design



Die Forschungsberichte des Instituts für Informatik und Wirtschaftsinformatik dienen der Darstellung vorläufiger Ergebnisse, die i. d. R. noch für spätere Veröffentlichungen überarbeitet werden. Die Autoren sind deshalb für kritische Hinweise dankbar.

---

The ICB Research Reports comprise preliminary results which will usually be revised for subsequent publications. Critical comments would be appreciated by the authors.

---

Alle Rechte vorbehalten. Insbesondere die der Übersetzung, des Nachdruckes, des Vortrags, der Entnahme von Abbildungen und Tabellen – auch bei nur auszugsweiser Verwertung.

---

All rights reserved. No part of this report may be reproduced by any means, or translated.

---

#### **Authors' Address:**

Felix Föcker  
University of Duisburg-Essen  
Universitätsstr. 2, 45127 Essen, Germany

[felix.foecker@uni-due.de](mailto:felix.foecker@uni-due.de)

Frank Houdek  
Daimler AG  
Postfach 2360, 89013 Ulm, Germany

[frank.houdek@daimler.com](mailto:frank.houdek@daimler.com)

Marian Daun, Thorsten Weyer  
paluno, University of Duisburg-Essen  
Gerlingstr. 16, 45127 Essen, Germany

[marian.daun@paluno.uni-due.de](mailto:marian.daun@paluno.uni-due.de)

[thorsten.weyer@paluno.uni-due.de](mailto:thorsten.weyer@paluno.uni-due.de)

---

#### **ICB Research Reports**

##### **Edited by:**

Prof. Dr. Heimo Adelsberger  
Prof. Dr. Frederik Ahlemann  
Prof. Dr. Klaus Echtele  
Prof. Dr. Stefan Eicker  
Prof. Dr. Ulrich Frank  
Prof. Dr. Michael Goedicke  
Prof. Dr. Volker Gruhn  
PD Dr. Christina Klüver  
Prof. Dr. Tobias Kollmann  
Prof. Dr. Klaus Pohl  
Prof. Dr. Erwin P. Rathgeb  
Prof. Dr. Rainer Unland  
Prof. Dr. Stephan Zelewski

#### **Contact:**

Institute for Computer Science and Business  
Information Systems (ICB)  
University of Duisburg-Essen  
Universitätsstr. 9  
45141 Essen, Germany

Tel.: 0201-183-4041

Fax: 0201-183-4011

Email: [icb@uni-duisburg-essen.de](mailto:icb@uni-duisburg-essen.de)

ISSN 1860-2770 (Print)  
ISSN 1866-5101 (Online)



## Abstract

Model-based engineering is a well-established approach to cope with the complexity of today's embedded systems. Furthermore, model-based engineering can address industry needs for highly automated development solutions to foster correctness of safety-critical systems. In contrast, there is a vital lack of accessible specification documents for researchers for evaluation purposes. Evaluation of proposed engineering methods often relies on academic examples, automatically created unrealistic artificial models, or simple industrial specification excerpts. This research report aims at supporting researchers with model-based specifications of a real-world system on a competitive level of complexity. Therefore, a model-based specification of an Adaptive Exterior Lighting System (ELS) is presented that is part of an Automotive System Cluster (ASC). An ELS provides fundamental and additional functionalities for the well-known turn signal and low / high beam headlights. The specification documents the behavioral requirements and the functional design of the ELS, which are important artifacts in function-centered engineering. As modeling languages ITU Message Sequence Charts, Function Network, and Function Behavior Diagrams are used.



# Table of Content

<b>1</b>	<b>INTRODUCTION .....</b>	<b>1</b>
1.1	MOTIVATION .....	1
1.2	THE AUTOMOTIVE SYSTEM CLUSTER .....	1
1.3	FUNCTION-CENTERED ENGINEERING .....	2
1.3.1	<i>Behavioral Requirements</i> .....	2
1.3.2	<i>Functional Design</i> .....	3
<b>2</b>	<b>SPECIFICATION OF THE BEHAVIORAL REQUIREMENTS.....</b>	<b>4</b>
2.1	STRUCTURE OF THE BEHAVIORAL REQUIREMENTS.....	5
2.2	CHANGE SETTINGS.....	5
2.2.1	<i>Set Rotary Light Switch</i> .....	6
2.2.2	<i>Set Pitman Arm</i> .....	7
2.2.3	<i>Set Hazard Warning Light Switch</i> .....	12
2.2.4	<i>Set Instrument Cluster</i> .....	13
2.2.5	<i>Set Darkness Switch</i> .....	14
2.2.6	<i>Set Ignition Key</i> .....	15
2.3	CONTROL HEADLIGHTS .....	16
2.3.1	<i>Control High Beam Headlights</i> .....	17
2.3.2	<i>Control Low Beam Headlights</i> .....	23
2.3.3	<i>Handle Overvoltage</i> .....	33
2.4	CONTROL TURN SIGNAL .....	34
2.4.1	<i>Direction Blinking Left</i> .....	35
2.4.2	<i>Direction Blinking Right</i> .....	38
2.4.3	<i>Hazard Warning Light</i> .....	39
2.5	DETECT FAULTS.....	41
<b>3</b>	<b>SPECIFICATION OF THE FUNCTIONAL DESIGN.....</b>	<b>42</b>
3.1	STRUCTURE OF THE FUNCTIONAL DESIGN.....	45
3.2	CONTROL HEADLIGHTS .....	47
3.2.1	<i>Control High Beam Headlights</i> .....	48
3.2.2	<i>Control Low Beam Headlights</i> .....	52
3.2.3	<i>Handle Overvoltage</i> .....	63
3.3	CONTROL TURN SIGNAL.....	63
3.3.1	<i>Direction Blinking Left</i> .....	65



3.3.2	<i>Direction Blinking Right</i> .....	67
3.3.3	<i>Hazard Warning Light</i> .....	68
3.4	DEFECT FAULTS .....	69
4	REFERENCES .....	70

# Table of Figures

FIGURE 1: HMSC - <i>ADAPTIVE EXTERIOR LIGHTING SYSTEM</i> .....	5
FIGURE 2: HMSC - <i>CHANGE SETTINGS</i> .....	6
FIGURE 3: HMSC - <i>SET ROTARY LIGHT SWITCH</i> .....	6
FIGURE 4: MSC - <i>SWITCH TO AUTO</i> .....	7
FIGURE 5: MSC - <i>SWITCH TO EXTERIOR LIGHT ON</i> .....	7
FIGURE 6: MSC - <i>SWITCH TO OFF</i> .....	7
FIGURE 7: HMSC - <i>SET PITMAN ARM</i> .....	8
FIGURE 8: MSC - <i>ACTIVATE HIGH BEAM</i> .....	9
FIGURE 9: MSC - <i>DEACTIVATE HIGH BEAM</i> .....	9
FIGURE 10: MSC - <i>ACTIVATE DIRECTION INDICATOR</i> .....	10
FIGURE 11: MSC - <i>ACTIVATE PERMANANTLY</i> .....	10
FIGURE 12: MSC - <i>DEACTIVATE DIRECTION INDICATOR</i> .....	11
FIGURE 13: MSC - <i>SET HAZARD WARNING LIGHT SWITCH</i> .....	12
FIGURE 14: HMSC - <i>SET INSTRUMENT CLUSTER</i> .....	13
FIGURE 15: MSC - <i>SET DAYTIME TUNNING LIGHT</i> .....	13
FIGURE 16: MSC - <i>SET AMBIENT LIGHT</i> .....	13
FIGURE 17: MSC - <i>SET DARKNESS SWITCH</i> .....	14
FIGURE 18: HMSC - <i>SET IGNITION KEY</i> .....	15
FIGURE 19: MSC - <i>INSERT IGNITION KEY</i> .....	15
FIGURE 20: MSC - <i>REMOVE IGNITION KEY</i> .....	15
FIGURE 21: MSC - <i>START ENGINE</i> .....	16
FIGURE 22: MSC - <i>STOP ENGINE</i> .....	16
FIGURE 23: HMSC - <i>CONTROL HEADLIGHTS</i> .....	16
FIGURE 24: HMSC - <i>CONTROL HIGH BEAM HEADLIGHTS</i> .....	17
FIGURE 25: MSC - <i>ACTIVATE MANUAL HIGH BEAM HEADLIGHTS</i> .....	18
FIGURE 26: MSC - <i>ACTIVATE ADAPTIVE HIGH BEAM HEADLIGHTS</i> .....	19
FIGURE 27: MSC - <i>DEACTIVATE HIGH BEAM HEADLIGHTS</i> .....	20
FIGURE 28: MSC - <i>CHECK VOLTAGE</i> .....	21
FIGURE 29: MSC - <i>ADAPT HIGH BEAM HEADLIGHTS</i> .....	22
FIGURE 30: HMSC - <i>CONTROL LOW BEAM HEADLIGHTS</i> .....	23
FIGURE 31: HMSC - <i>ACTIVATE LOW BEAM HEADLIGHTS</i> .....	23
FIGURE 32: MSC - <i>ACTIVATE AMBIENT LIGHT</i> .....	24

FIGURE 33: MSC - <i>ACTIVATE DAYTIME RUNNING LIGHT</i> .....	25
FIGURE 34: MSC - <i>ACTIVATE LOW BEAM HEADLIGHTS MANUAL</i> .....	25
FIGURE 35: MSC - <i>ACTIVATE LOW BEAM HEADLIGHTS AUTOMATIC</i> .....	26
FIGURE 36: HMSC - <i>DEACTIVATE LOW BEAM HEADLIGHTS</i> .....	27
FIGURE 37: MSC - <i>DEACTIVATE AMBIENT LIGHT</i> .....	28
FIGURE 38: MSC - <i>DEACTIVATE DAYTIME RUNNING LIGHT</i> .....	29
FIGURE 39: MSC - <i>DEACTIVATE LOW BEAM HEADLIGHTS AUTOMATIC</i> .....	30
FIGURE 40: MSC - <i>DEACTIVATE LOW BEAM HEADLIGHTS MANUAL</i> .....	31
FIGURE 41: MSC - <i>CHECK CONDITIONS AND SWITCH OFF</i> .....	31
FIGURE 42: MSC - <i>CONTROL CORNERING LIGHT</i> .....	32
FIGURE 43: MSC - <i>HANDLE OVERVOLTAGE</i> .....	33
FIGURE 44: HMSC - <i>CONTROL TURNING LIGHTS</i> .....	34
FIGURE 45: MSC - <i>ACTIVATE DIRECTION BLINKING LEFT</i> .....	35
FIGURE 46: MSC - <i>ACTIVATE TIP BLINKING LEFT</i> .....	36
FIGURE 47: MSC - <i>DEACTIVATE DIRECTION BLINKING LEFT</i> .....	37
FIGURE 48: MSC - <i>ACTIVATE DIRECTION BLINKING RIGHT</i> .....	38
FIGURE 49: MSC - <i>DEACTIVATE DIRECTION BLINKING RIGHT</i> .....	38
FIGURE 50: MSC - <i>ACTIVATE TIP BLINKING RIGHT</i> .....	39
FIGURE 51: MSC - <i>CONTROL HAZARD WARNING LIGHT</i> .....	40
FIGURE 52: MSC - <i>DETECT FAULTS</i> .....	41
FIGURE 53: CONTEXT DIAGRAM .....	45
FIGURE 54: FUNCTION NETWORK DIAGRAM – <i>CONTROL ADAPTIVE EXTERIOR LIGHTING SYSTEM</i> .....	46
FIGURE 55: FUNCTION NETWORK DIAGRAM - <i>CONTROL HEADLIGHTS</i> .....	47
FIGURE 56: FUNCTION NETWORK DIAGRAM - <i>CONTROL HIGH BEAM HEADLIGHTS</i> .....	48
FIGURE 57: INTERFACE AUTOMATON - <i>ACTIVATE MANUAL HIGH BEAM HEADLIGHTS</i> .....	49
FIGURE 58: INTERFACE AUTOMATON - <i>ACTIVATE ADAPTIVE HIGH BEAM HEADLIGHTS</i> .....	49
FIGURE 59: INTERFACE AUTOMATON - <i>DEACTIVATE HIGH BEAM HEADLIGHTS</i> .....	50
FIGURE 60: INTERFACE AUTOMATON - <i>CHECK VOLTAGE</i> .....	50
FIGURE 61: INTERFACE AUTOMATON - <i>ADAPT HIGH BEAM HEADLIGHTS</i> .....	51
FIGURE 62: FUNCTION NETWORK DIAGRAM - <i>CONTROL LOW BEAM HEADLIGHTS</i> .....	52
FIGURE 63: FUNCTION NETWORK DIAGRAM - <i>ACTIVATE LOW BEAM HEADLIGHTS</i> .....	53
FIGURE 64: INTERFACE AUTOMATON - <i>ACTIVATE LOW BEAM HEADLIGHTS MANUAL</i> .....	54
FIGURE 65: INTERFACE AUTOMATON - <i>ACTIVATE LOW BEAM HEADLIGHTS AUTOMATIC</i> .....	54

FIGURE 66: INTERFACE AUTOMATON - <i>ACTIVATE DAYTIME RUNNING LIGHT</i> .....	55
FIGURE 67: FUNCTION NETWORK DIAGRAM - <i>ACTIVATE AMBIENT LIGHT</i> .....	56
FIGURE 68: INTERFACE AUTOMATON - <i>CHECK CONDITIONS</i> .....	57
FIGURE 69: INTERFACE AUTOMATON - <i>ACTIVATE BY KEY</i> .....	57
FIGURE 70: INTERFACE AUTOMATON - <i>ACTIVATE BY DOOR</i> .....	57
FIGURE 71: FUNCTION NETWORK DIAGRAM - <i>DEACTIVATE LOW BEAM HEADLIGHTS</i> .....	58
FIGURE 72: INTERFACE AUTOMATON - <i>DEACTIVATE LOW BEAM HEADLIGHTS MANUAL</i> .....	59
FIGURE 73: INTERFACE AUTOMATON - <i>DEACTIVATE LOW BEAM HEADLIGHTS AUTOMATIC</i> .....	59
FIGURE 74: INTERFACE AUTOMATON - <i>DEACTIVATE DAYTIME RUNNING LIGHT</i> .....	59
FIGURE 75: INTERFACE AUTOMATON - <i>DEACTIVATE AMBIENT LIGHT</i> .....	60
FIGURE 76: INTERFACE AUTOMATON - <i>CHECK CONDITIONS AND SWITCH OFF</i> .....	60
FIGURE 77: FUNCTION NETWORK DIAGRAM - <i>CONTROL CORNERING LIGHT</i> .....	61
FIGURE 78: INTERFACE AUTOMATON - <i>CHECK CONDITIONS</i> .....	62
FIGURE 79: INTERFACE AUTOMATON - <i>ACTIVATE LEFT CORNERING LIGHT</i> .....	62
FIGURE 80: INTERFACE AUTOMATON - <i>DEACTIVATE LEFT CORNERING LIGHT</i> .....	62
FIGURE 81: INTERFACE AUTOMATON - <i>ACTIVATE RIGHT CORNERING LIGHT</i> .....	63
FIGURE 82: INTERFACE AUTOMATON - <i>DEACTIVATE RIGHT CORNERING LIGHT</i> .....	63
FIGURE 83: INTERFACE AUTOMATON - <i>HANDLE OVERVOLTAGE</i> .....	63
FIGURE 84: FUNCTION NETWORK DIAGRAM - <i>CONTROL TURN LIGHTS (MESSAGES)</i> .....	64
FIGURE 85: FUNCTION NETWORK DIAGRAM - <i>CONTROL TURN LIGHTS (DEPENDENCIES)</i> .....	65
FIGURE 86: INTERFACE AUTOMATON - <i>ACTIVATE DIRECTION BLINKING LEFT</i> .....	66
FIGURE 87: INTERFACE AUTOMATON - <i>DEACTIVATE DIRECTION BLINKING LEFT</i> .....	66
FIGURE 88: INTERFACE AUTOMATON - <i>ACTIVATE TIP BLINKING LEFT</i> .....	66
FIGURE 89: INTERFACE AUTOMATON - <i>ACTIVATE DIRECTION BLINKING RIGHT</i> .....	67
FIGURE 90: INTERFACE AUTOMATON - <i>ACTIVATE TIP BLINKING RIGHT</i> .....	67
FIGURE 91: INTERFACE AUTOMATON - <i>DEACTIVATE DIRECTION BLINKING RIGHT</i> .....	67
FIGURE 92: INTERFACE AUTOMATON - <i>ACTIVATE HAZARD WARNING LIGHT</i> .....	68
FIGURE 93: INTERFACE AUTOMATON - <i>DEACTIVATE HAZARD WARNING LIGHT</i> .....	69
FIGURE 94: INTERFACE AUTOMATON - <i>DETECT FAULTS</i> .....	69



# 1 Introduction

This research report presents model-based specifications of an Adaptive Exterior Lighting System (ELS), which is part of an Automotive System Cluster (ASC). The specifications document the behavioral requirements and the functional design of the ELS, which are important artifacts in function-centered engineering. As modeling languages, ITU Message Sequence Charts (cf. (ITU 2011)) and Function Network and Function Behavior Diagrams (cf. (Daun et al 2014)) are used.

## 1.1 Motivation

Model-based engineering is a well-established approach to cope with the complexity of today's embedded systems (cf. (Beetz and Böhm 2012)). Furthermore, model-based engineering can address industry needs for highly automated development solutions to foster correctness of safety-critical systems (cf. (Sikora et al 2012)). In contrast, there is a vital lack of accessible specification documents for researchers for evaluation purposes. Evaluation of proposed engineering methods often relies on academic examples, automatically created unrealistic artificial models, or simple industrial specification excerpts. This research report aims at supporting researchers with model-based specifications of a real-world system on a competitive level of complexity.

The specifications were developed as part of the SPES evaluation strategy during the joint research project SPES 2020 XTCORE. The behavioral requirements specification (Section 2) is a result of the application of SPES specification techniques for the model-based documentation of requirements (cf. (Daun et al 2012)). The specification of the functional design (Section 3) results from the application of techniques described in (Daun et al 2014). In conclusion, the specifications document the applicability of the proposed approaches. Hence, the given specifications are the basis for further research and evaluation activities regarding the application of validation, verification, and model transformation approaches, which make use of behavioral requirements and functional design.

## 1.2 The Automotive System Cluster

The ASC can be considered as a comfort control system that consists of two subsystems, namely the ELS and an Adaptive Cruise Control System (ACC). While this research report provides insights into the model-based specification of the ELS, a natural language description of the ASC's system requirements specification can be found in (Houdek 2013).

An ELS provides fundamental and additional functionalities for the well-known turn signal and low / high beam headlights. For example, the control of the driving direction indicators of the vehicle in dependence of the pitman arm, the control of the low beam headlights in

dependence of the light rotary switch and the daytime running light settings, and the control of the high beam headlights in dependence of the high beam switch and the detection of advancing vehicles.

### **1.3 Function-Centered Engineering**

In the development of embedded systems, function-centered engineering is a commonly used approach to cope with the emerging number and complexity of systems' software functions and their interdependencies (cf. (Pretschner et al 2007)). Function-centered engineering focuses on the functional design as the central development artifact throughout the whole engineering process.

As described in (Brinkemper and Pachidi 2010) and (Jantsch and Sander 2000), the functional design specifies the functions to be implemented, their hierarchical structure, and the planned behavior of each function. In addition, it specifies interactions and dependencies between the functions in such a way that the interplay between different functions fulfills the behavioral properties documented in the behavioral requirements (e.g., to optimize the function deployment and thereby to minimize the number of expensive electronic control units, to avoid redundancies affecting the maintainability of the system, or to foster re-use of implemented functions). The initial version of the functional design is based on the behavioral requirements that are in turn reflecting the consolidated stakeholder intentions with respect to the system to be built.

Next, the behavioral requirements and the functional design are briefly characterized as outlined in (Daun et al 2014).

#### **1.3.1 Behavioral Requirements**

In general, behavioral requirements models can be differentiated into state-based and interaction-based models. During requirements engineering, especially interaction-based models are widely used, for example, to document scenarios and to specify the essential interfaces.

In the engineering of embedded software, message sequence charts (MSCs) are commonly used for the specification of interaction-based behavioral requirements models (cf. (Weber and Weisbrod 2002)). The Z.120 standard (ITU 2011) distinguishes between basic message sequence charts (bMSCs) and high-level message sequence charts (hMSCs). bMSCs define specific situations detailing the behavior in terms of messages exchanged between the system and entities in the environment. hMSCs structure the bMSCs according to their execution order and create a complete system specification.

### 1.3.2 Functional Design

The functional design consists of specifications of the system functions to be implemented and their hierarchical structure. Additionally, the intended behavior of each system function is specified as well as the interactions and dependencies between system functions.

Different diagram types are used to document the functional design. Function network diagrams document the functional dependencies between system functions that are embedded in given context functions. Context functions are functions that can be used by the system to be built but are not a subject of the development process. Afterwards, each function is detailed by a function behavior diagram that specifies the behavior of the function in terms of an interface automaton (cf. (de Alfaro and Henzinger 2001)).



## 2 Specification of the Behavioral Requirements

The model-based specification of behavioral requirements - as described in the following - comprises the combinations of MSCs of the ELS in hMSCs and more detailed interactions in bMSCs. The Structure (highest abstraction-level) of the behavioral requirements is described in Section 2.1. Breaking down the hMSCs to bMSCs results in up to five abstraction-levels. The sections 2.2, 2.3, 2.4, and 2.5 represent the second abstraction-level and the main functions of the ELS as outlined above.

The specified instances of the ELS are subdivided into system- and context-instances. An overview is given in Table 1. For an improved identification, the instances are represented by different fillings of the shapes.

**Table 1: MSC Instances**

Instance	Shape
Body Controller	<div style="display: flex; flex-direction: column; align-items: center;"> <div style="text-align: center;">Context Instance</div> <div style="width: 40px; height: 15px; border: 1px solid black; margin: 0 auto;"></div> <div style="width: 1px; height: 100%; border: 1px solid black; margin: 0 auto;"></div> <div style="width: 40px; height: 15px; border: 1px solid black; background: repeating-linear-gradient(45deg, transparent, transparent 2px, black 2px, black 4px); margin: 0 auto;"></div> </div>
Camera Unit	
Darkness Switch	
Door Control Unit	
Driver	
ESP Control Unit	
Hazard Warning Light Switch	
High Beam Module	
Ignition Key	
Pitman Arm	
Roof Console Control Unit	
Rotary Light Switch	
Adaptive High Beam Headlight	
Defect Detection	
Instrument Cluster	
Low Beam Headlight	
Turning Light	

## 2.1 Structure of the Behavioral Requirements

The behavioral requirements are structured into four referenced MSCs that are applicable in a loop (see Figure 1). These referenced MSCs represent the main functionalities of the ELS to change the global settings of the system by a user, to control the headlights and the turn signal, and to detect faults.

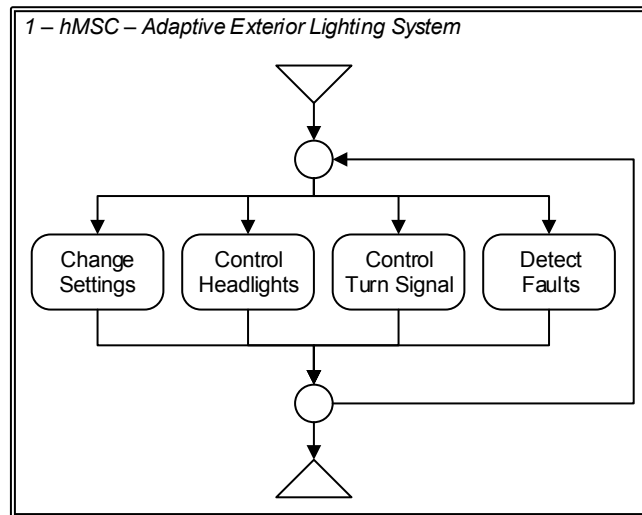

Figure 1: hMSC - Adaptive Exterior Lighting System

## 2.2 Change Settings

In Figure 1, all required settings of the system are condensed and refer to the appropriate MSC. It is either possible to set the rotary light switch (see Section 2.2.1), the pitman arm (see Section 2.2.2), the hazard warning light switch (see Section 2.2.3), the instrument cluster (see Section 2.2.4), the darkness switch (see Section 2.2.5), or the ignition key (see Section 2.2.6).

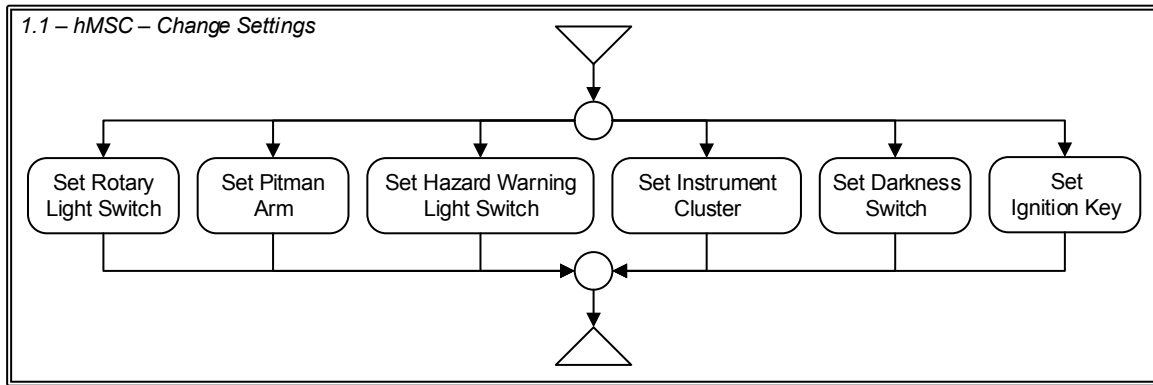

Figure 2: hMSC - Change Settings

### 2.2.1 Set Rotary Light Switch

The Rotary Light Switch is a part of the user interface and has three positions (left - "Off", middle - "Auto" and right - "Exterior Light On"), which represent the modes of the low beam headlight. In Figure 3, the possible combinations to switch these modes are presented. The position "Off" and "Exterior Light On" can only be reached from position "Auto", and "Auto" can only be reached from "Off" and "Exterior Light On".

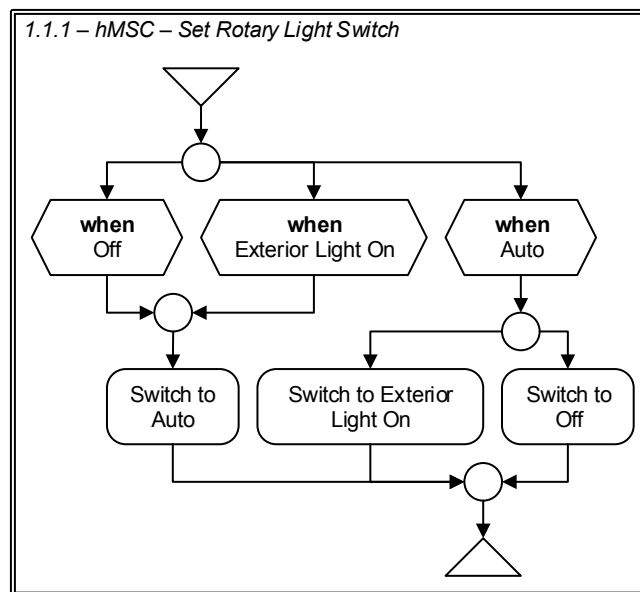

Figure 3: hMSC - Set Rotary Light Switch

If the *Driver* wants to switch the position and the conditions are fulfilled, he adjusts the switch and the *Rotary Light Switch* changes its mode and the conditions (see Figure 4, Figure 5, and Figure 6).

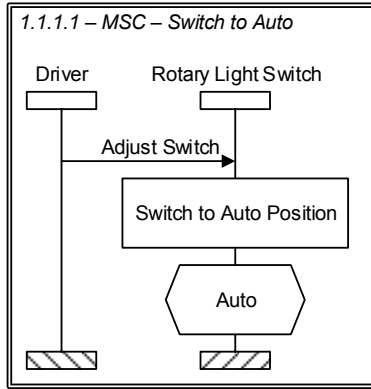

Figure 4: MSC - Switch to Auto

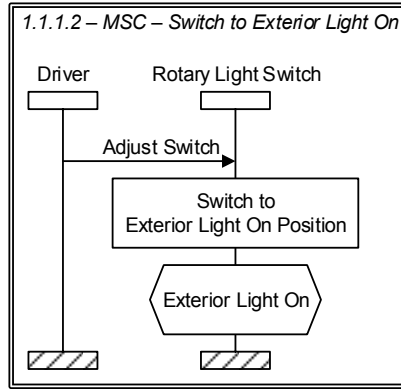

Figure 5: MSC - Switch to Exterior Light On

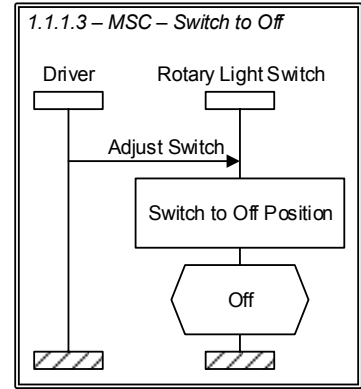

Figure 6: MSC - Switch to Off

### 2.2.2 Set Pitman Arm

The Pitman Arm is a control lever attached to the steering column and part of the user interface. By switching its position, the Pitman Arm provides the functionalities to activate or deactivate the high beam and the direction indicators (see Figure 7). Basically, it is possible to adjust the Pitman Arm on the horizontal and the vertical axis. When the Pitman Arm is in the horizontal neutral position the high beam can be activated and when the Pitman Arm is in a vertical neutral position the direction indicator can be activated. Subsequently, an activated direction indicator can be activated permanently by engaging the vertical position of the Pitman Arm. In the following, the referenced bMSCs are described and provide detailed information about the positions of the Pitman Arm.

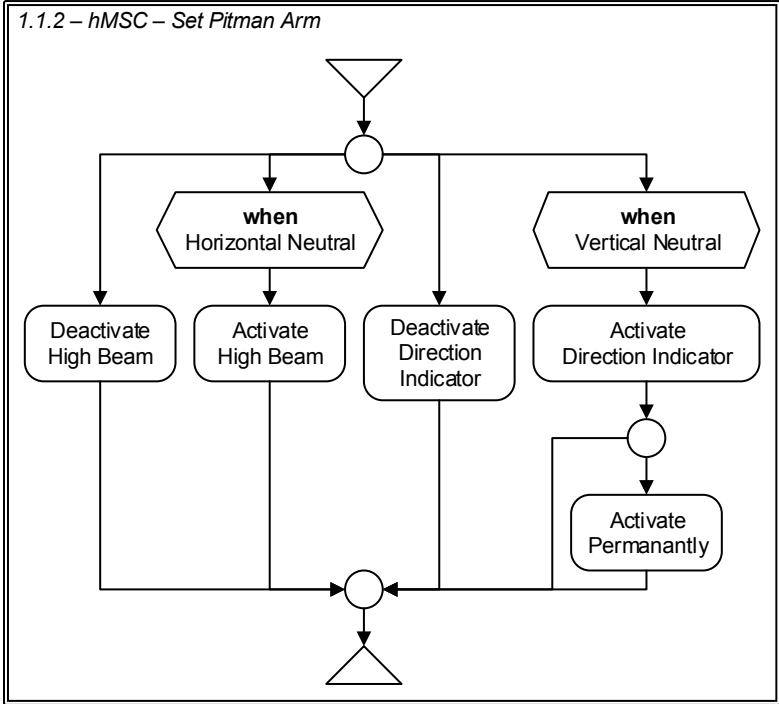

Figure 7: hMSC - Set Pitman Arm

**High Beam Headlights.** If the *Driver* wants to activate the high beam headlights, he can either push away and engage or pull and hold the *Pitman Arm* (see Figure 8). By pushing away and engaging the Pitman Arm, the high beam headlights and the adaptive high beam are activated permanently. To activate the high beam headlights temporary (so called flasher), the *Driver* needs to pull and hold the *Pitman Arm*. To deactivate the high beam headlights, the *Driver* either needs to release the *Pitman Arm* from the pulled position or disengage it from the pushed position (see Figure 9).

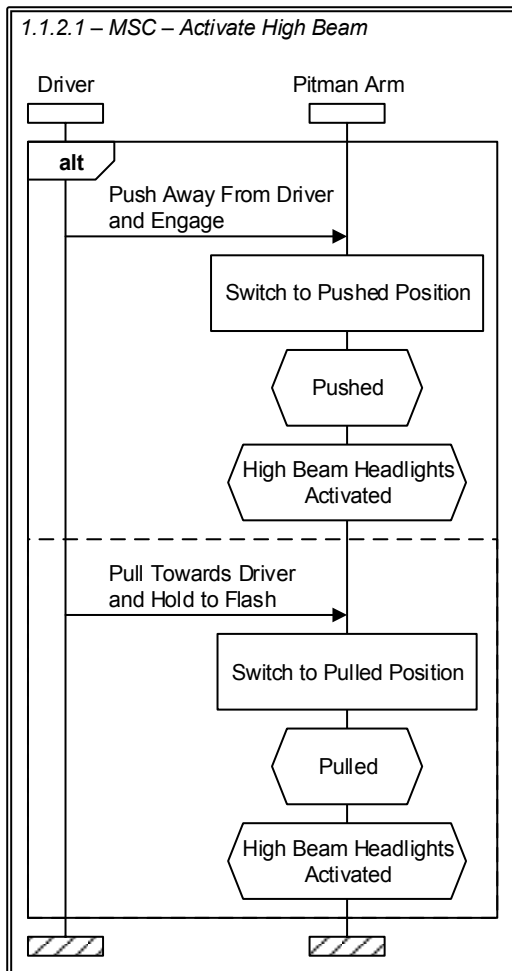

Figure 8: MSC - Activate High Beam

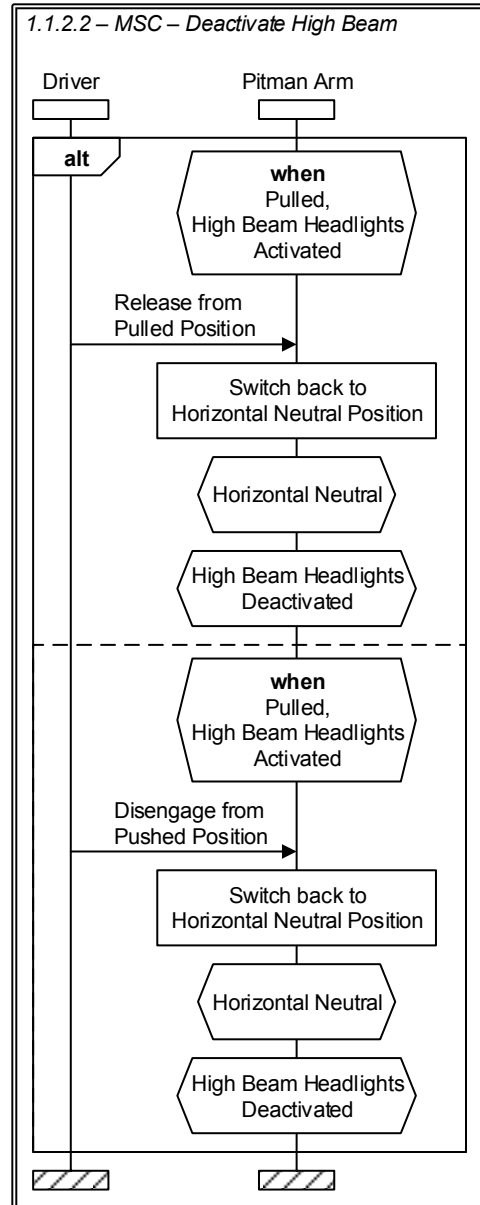

Figure 9: MSC - Deactivate High Beam

**Direction Indicator.** The *Driver* can either activate the left or right direction indicators by moving the *Pitman Arm* down or up (see Figure 10). The distinction between temporary and permanent activation of the direction indicators is made by the Pitman Arm deflection. If the *Pitman Arm* is engaged by the *Driver*, the direction indicators are activated permanently, otherwise temporarily (see Figure 11).

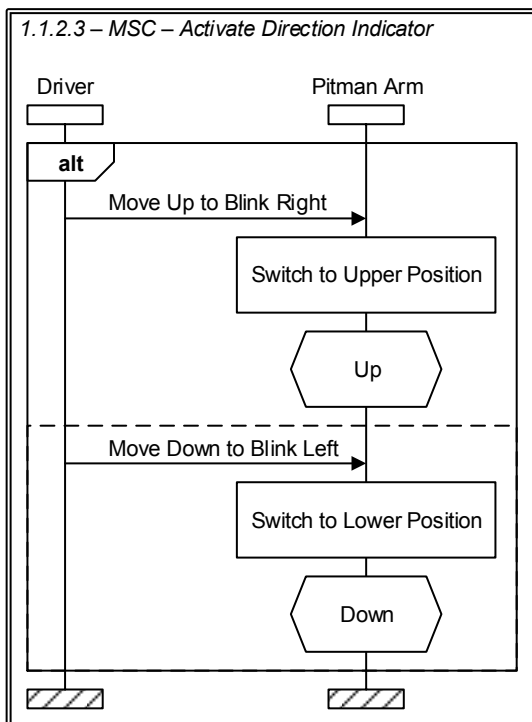

Figure 10: MSC - Activate Direction Indicator

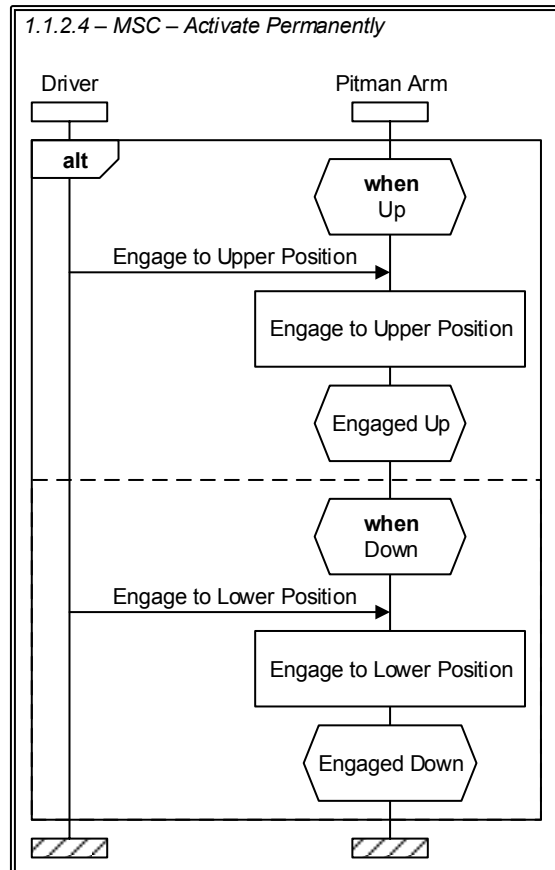

Figure 11: MSC - Activate Permanently

To deactivate the direction indicators, the *Driver* needs to disengage or release the *Pitman Arm* from the upper or lower position (see Figure 12).

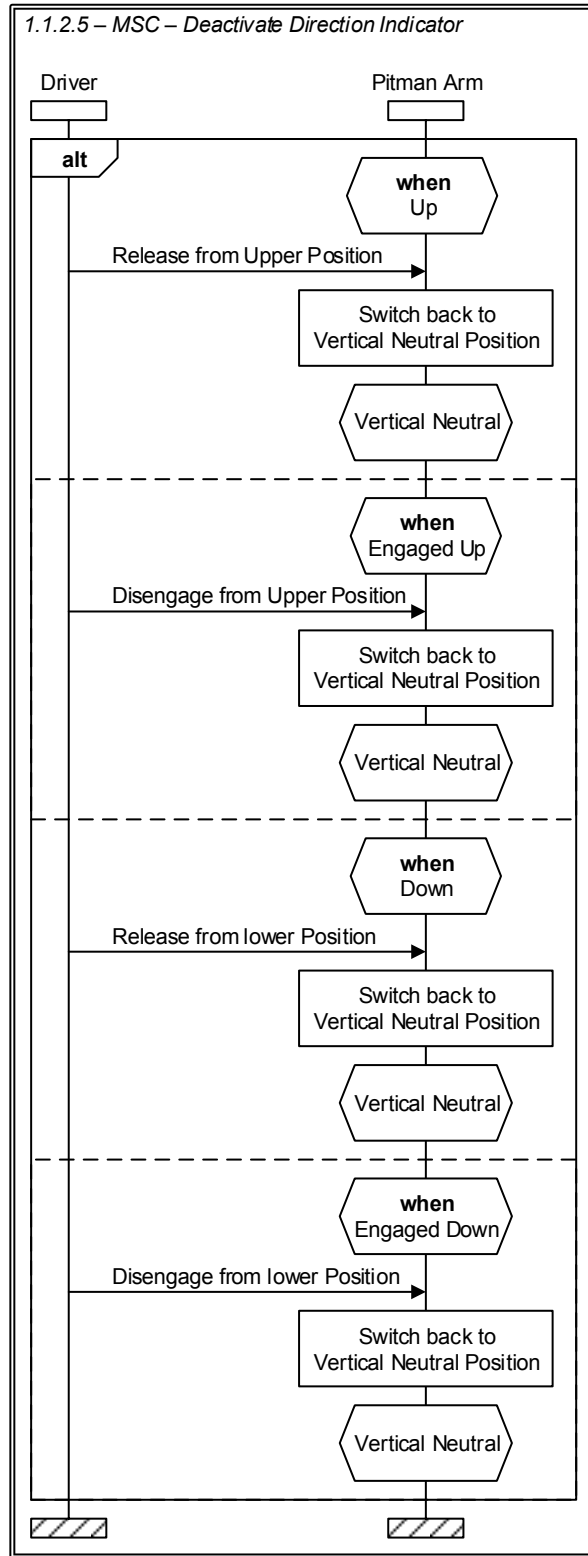

Figure 12: MSC - Deactivate Direction Indicator



### 2.2.3 Set Hazard Warning Light Switch

The Hazard Warning Light Switch is also part of the user interface and can either be switched “On” or “Off” (see Figure 13). When the *Driver* switches the *Hazard Warning Light Switch* on, the hazard warning light gets activated - otherwise deactivated.

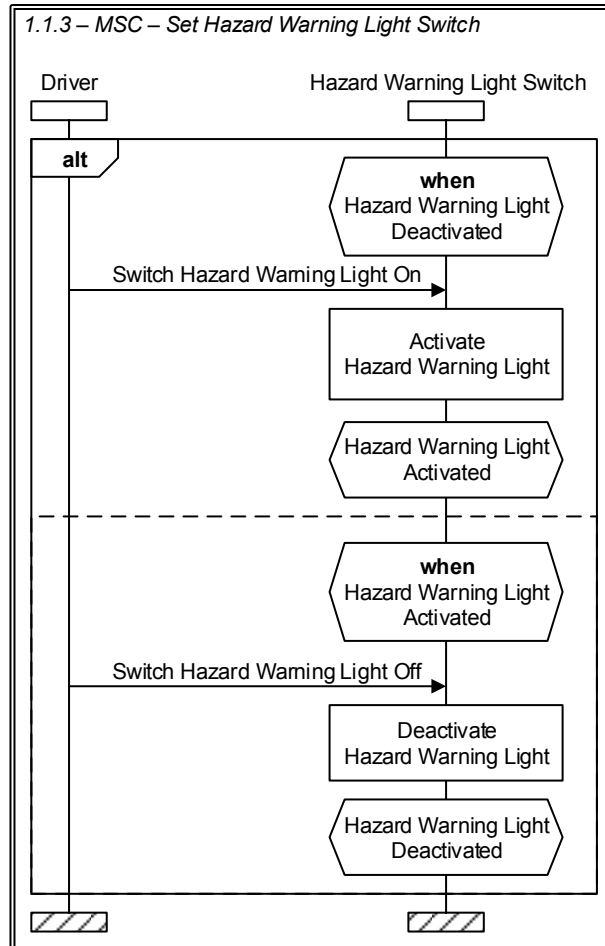

Figure 13: MSC - Set Hazard Warning Light Switch

### 2.2.4 Set Instrument Cluster

The Instrument Cluster provides access to additional settings for the low beam headlights. Either the settings for the daytime running light or the settings for the ambient light could be accessed (see Figure 14).

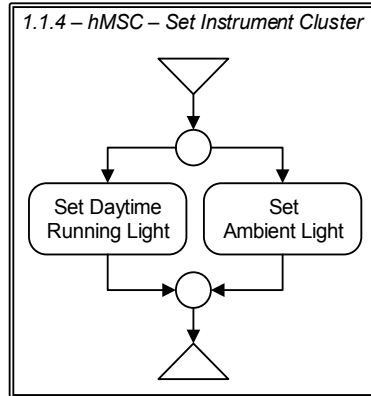

Figure 14: hMSC - Set Instrument Cluster

The Daytime Running Light can be activated or deactivated by the *Driver* in the *Instrument Cluster* in the menu "Settings, Vehicle settings, Daytime running light" (see Figure 15). Furthermore, the Ambient Light can be activated or deactivated in the menu "Settings, Vehicle settings, Ambient lighting" (see Figure 16).

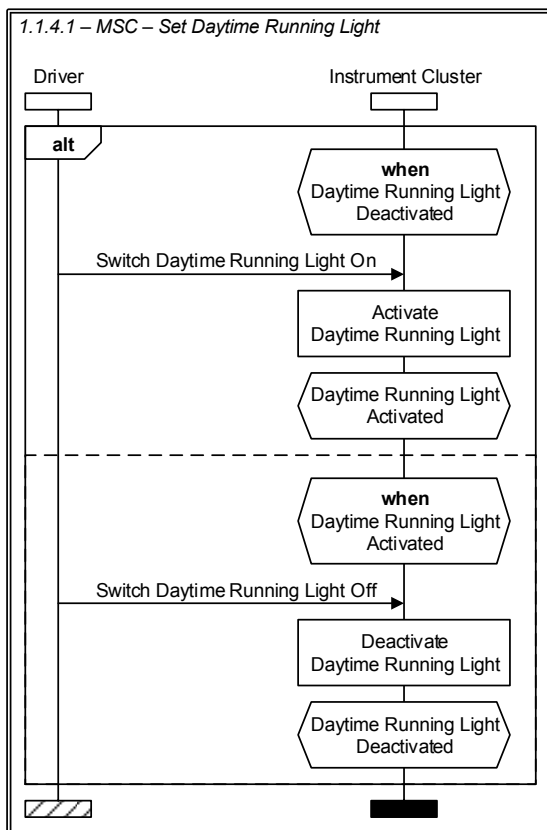

Figure 15: MSC - Set Daytime Running Light

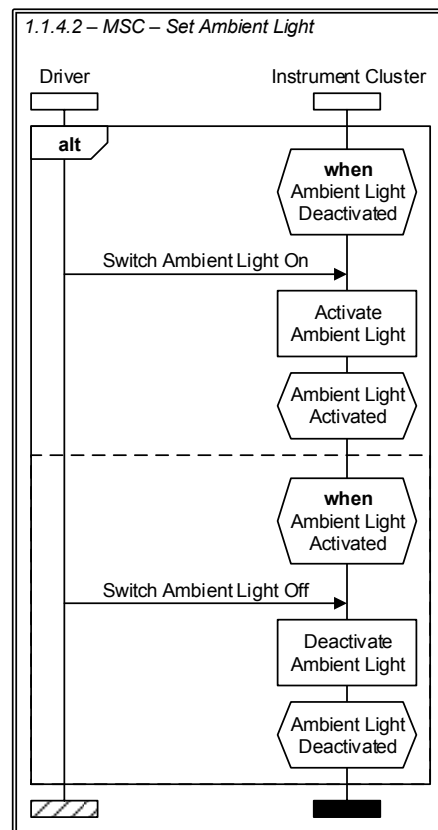

Figure 16: MSC - Set Ambient Light

### 2.2.5 Set Darkness Switch

The Darkness Switch is part of the user interface and mounted in the area of the upper control field - but only available in armored vehicles. If the *Darkness Switch* is available, the *Driver* can activate or deactivate the Darkness Mode (see Figure 17).

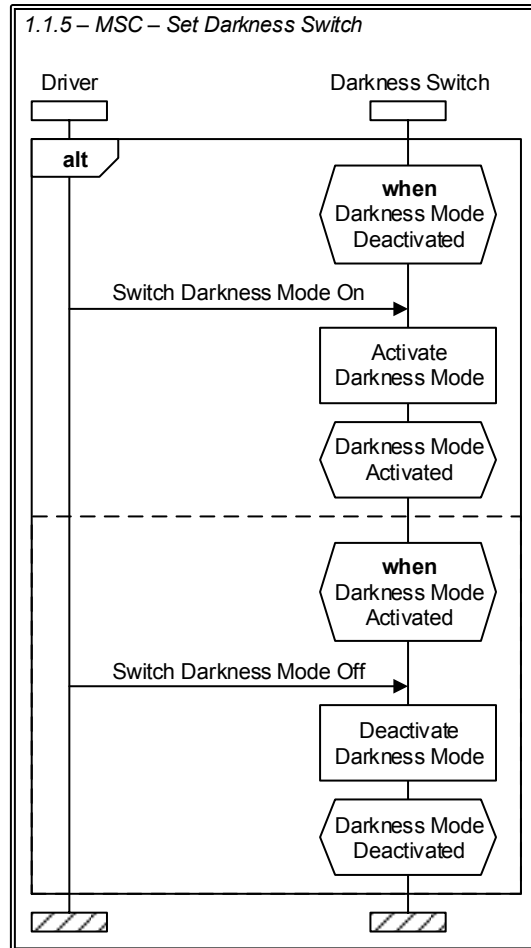

Figure 17: MSC - Set Darkness Switch

### 2.2.6 Set Ignition Key

A simplified model of the Ignition Key is presented in Figure 18 to ensure a consistent behavior of the ELS. First of all, the key could be inserted. When the key is inserted, the engine could be started or stopped. As long as the engine is stopped, it is possible to remove the key.

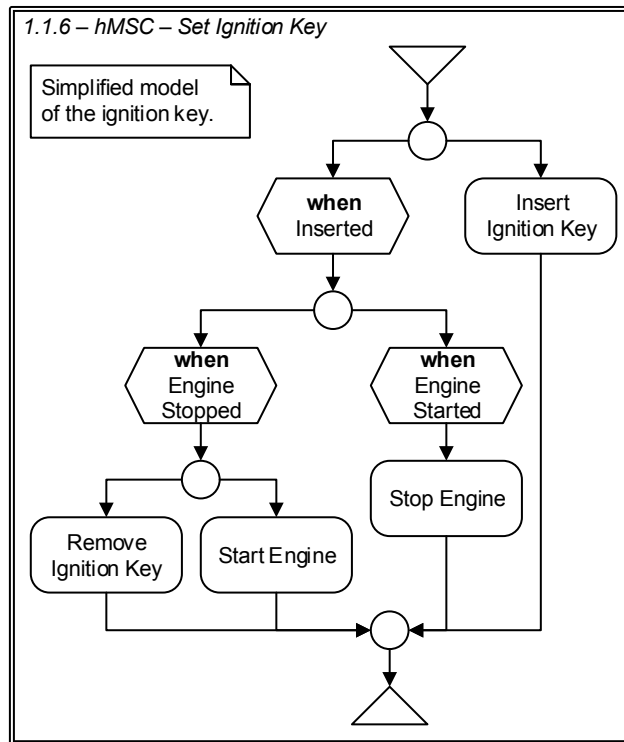

Figure 18: hMSC - Set Ignition Key

All referenced MSCs in Figure 18 need to be initialized by the Driver and lead to a change of the local conditions of the Ignition Key (see Figure 19, Figure 20, Figure 21, and Figure 22).

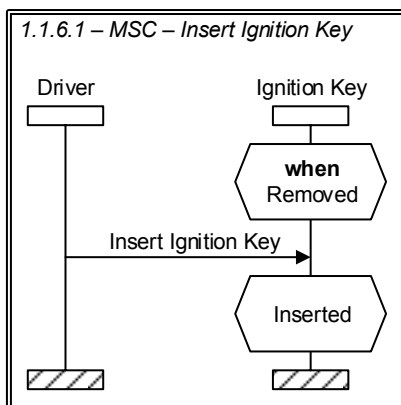

Figure 19: MSC - Insert Ignition Key

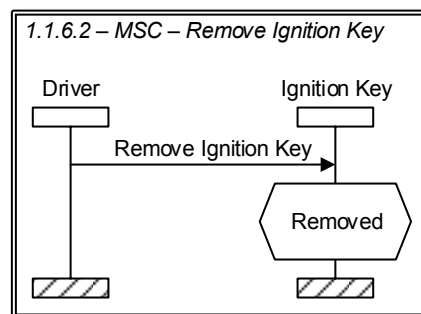

Figure 20: MSC - Remove Ignition Key

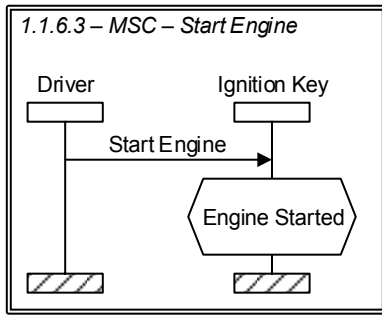

Figure 21: MSC - Start Engine

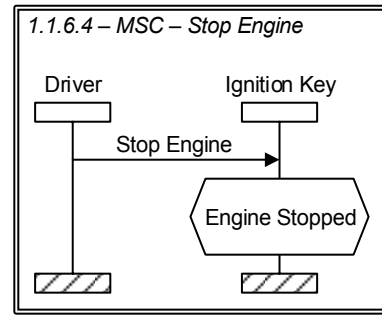

Figure 22: MSC - Stop Engine

## 2.3 Control Headlights

The control of the headlights (see Figure 23) comprises the control of the high beam headlights (see Section 2.3.1), the control of the low beam headlights (see Section 2.3.2) and the handling of overvoltage (see Section 2.3.3).

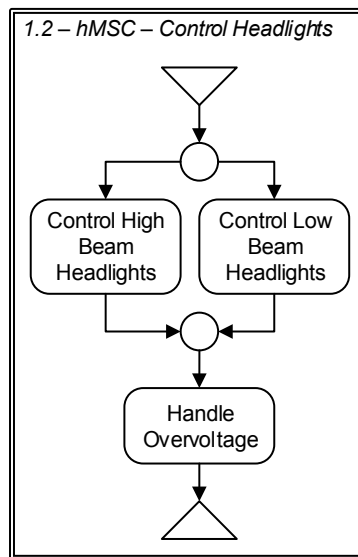

Figure 23: hMSC - Control Headlights

### 2.3.1 Control High Beam Headlights

The behavioral requirements for the control of the high beam headlights are structured in Figure 24. Either the high beam headlights are activated or deactivated. When the high beam headlights are deactivated, the manual or adaptive high beam headlights could be activated (see Section 2.3.1.1). Subsequently either the voltage is checked and the high beam headlight gets adapted (see Section 2.3.1.3) or the high beam headlights could be deactivated (see Section 2.3.1.2) if they were activated.

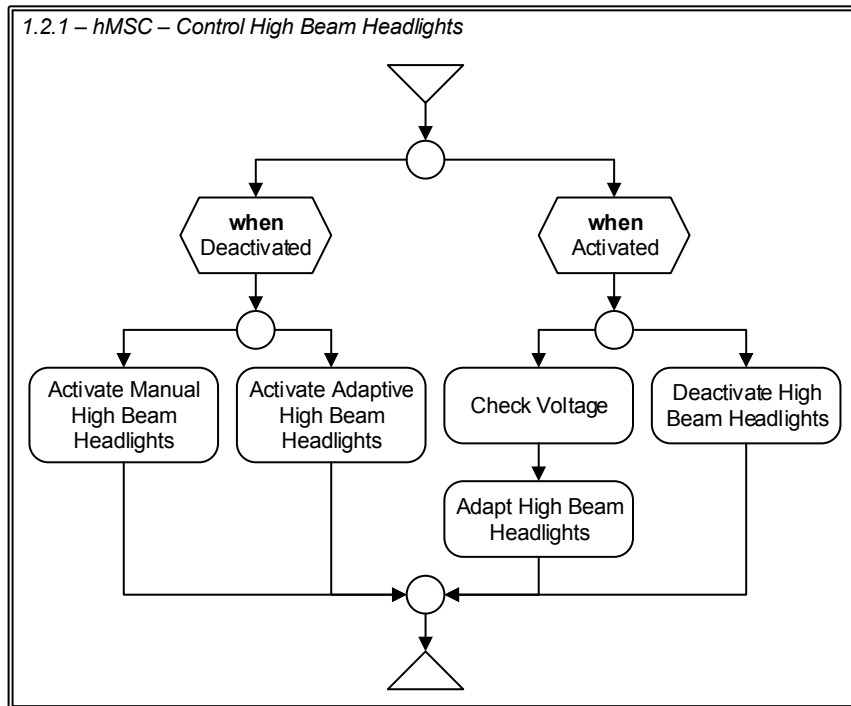

Figure 24: hMSC - Control High Beam Headlights

### 2.3.1.1 Activate High Beam Headlights

When the high beam headlights are activated by the *Pitman Arm* and the *Rotary Light Switch* is in “Off”- or “Exterior Light On”-Position the *Adaptive High Beam Headlight* switches to activated and activates the high beam headlights with a fixed illumination area of 220m due to the *High Beam Module* (see Figure 25). The activation via the Pitman Arm includes the so-called flasher (see Section 2.2.2).

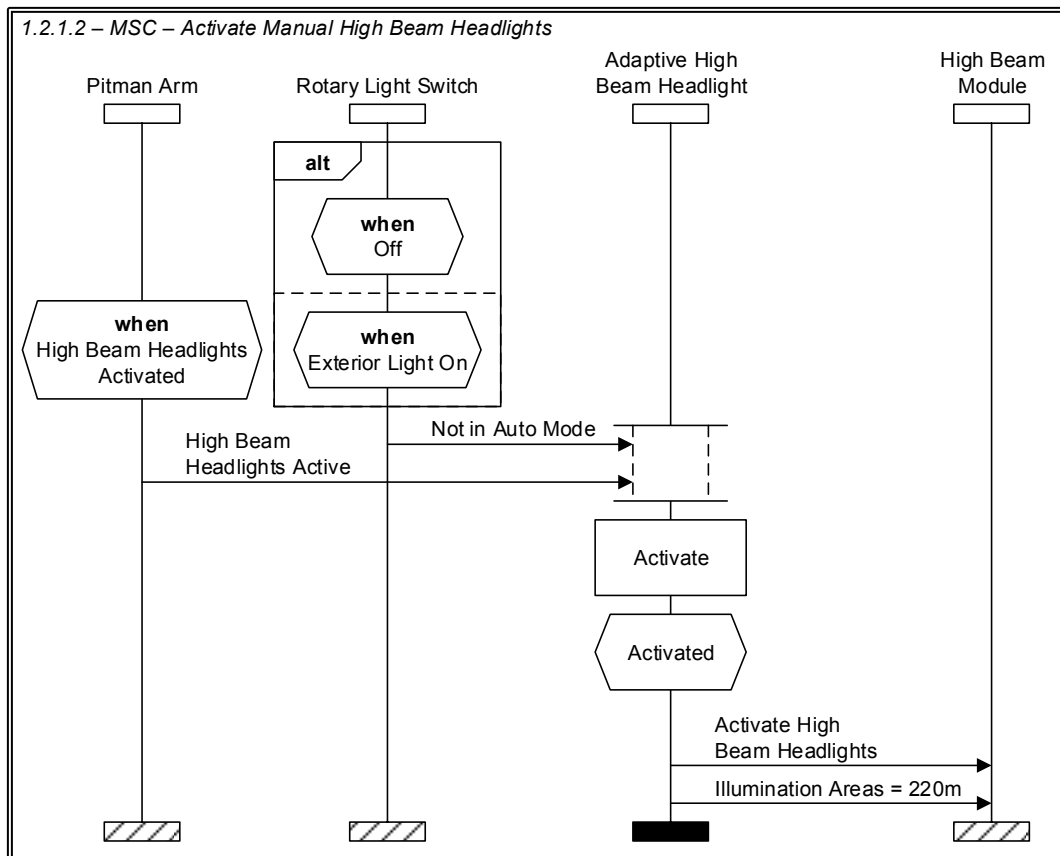

Figure 25: MSC - Activate Manual High Beam Headlights

The activation of the adaptive high beam headlight is initialized by the pushed position of the *Pitman Arm* and the auto mode of the *Rotary Light Switch* (see Figure 26). After activating the high beam headlights at the *High Beam Module*, the voltage needs to be checked. The adaption of the high beam headlights is not available with subvoltage and the illumination area is set to default. Otherwise, the adaption is activated and the operational availability of is indicated by a symbol in the *Instrument Cluster*.

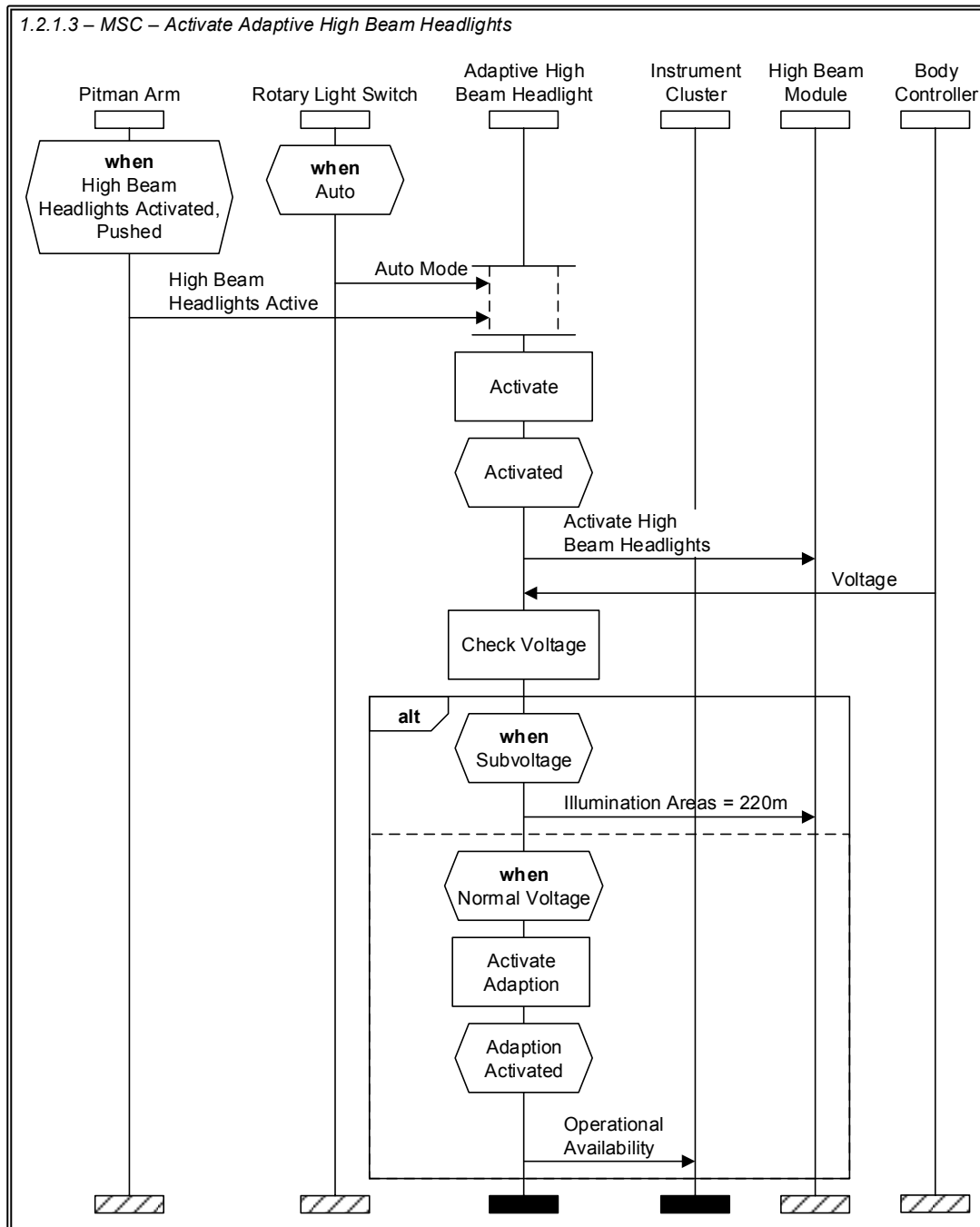

Figure 26: MSC - Activate Adaptive High Beam Headlights



### 2.3.1.2 Deactivate High Beam Headlights

When the *Pitman Arm* is moved again in the horizontal neutral position, the *Adaptive High Beam Headlight* is deactivated immediately (see Figure 27). Furthermore the adaption is deactivated (if necessary) and the operational availability is updated in the *Instrument Cluster*.

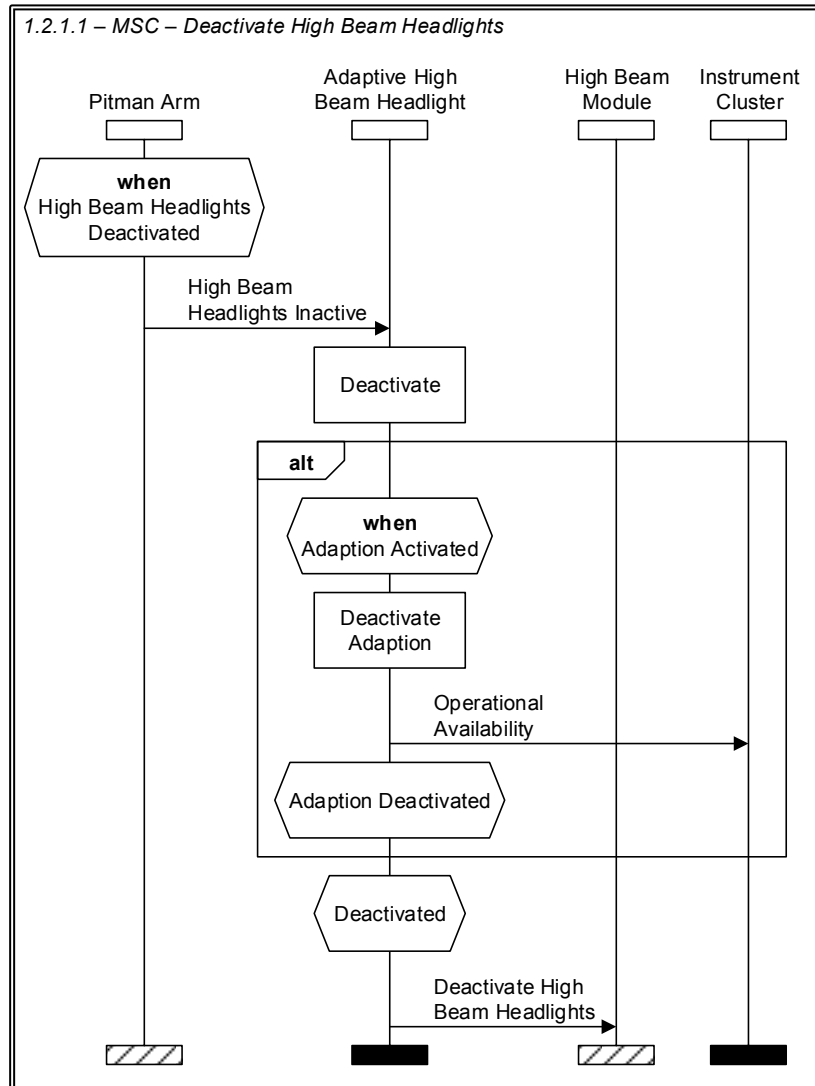

Figure 27: MSC - Deactivate High Beam Headlights

### 2.3.1.3 Check Voltage and Adapt High Beam Headlights

Before the high beam headlight gets adapted, the voltage needs to be checked again (see Figure 28 and Figure 26).

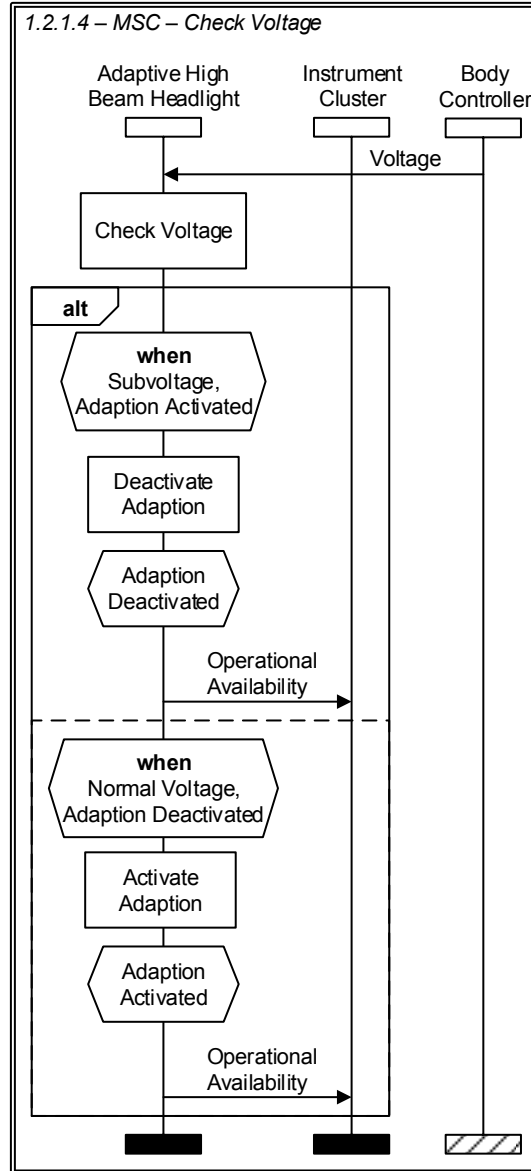

Figure 28: MSC - Check Voltage

## Specification of the Behavioral Requirements

When the adaption is activated and the *Camera* recognizes the lights of an advancing vehicle, activated high beam headlights are reduced to low beam headlights within 0.5 seconds by reducing the illumination area to 65m in the *High Beam Module*. If no advancing vehicle is recognized any more, the high beam illumination is restored within 2 seconds and the illumination area is within 100m and 300m, depending on the vehicle speed.

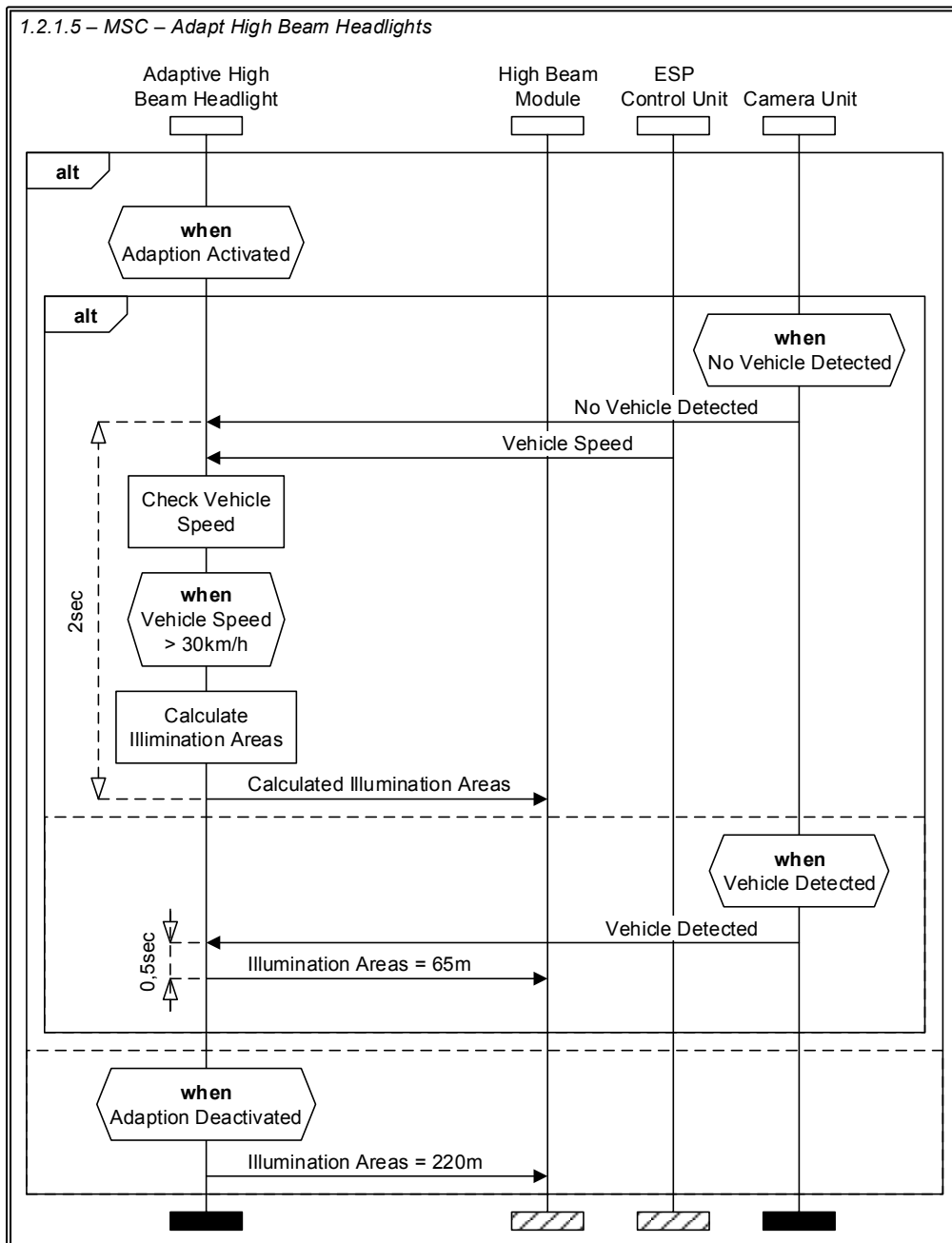

Figure 29: MSC - Adapt High Beam Headlights

### 2.3.2 Control Low Beam Headlights

In Figure 30, the allowed combinations of the activation and deactivation of the low beam headlights as well as the control of the cornering light are presented. The activation of the low beam headlights can be done under several conditions (see Section 2.3.2.1). When the low beam headlights are activated, they could either be deactivated (see Section 2.3.2.2) or the cornering light could be controlled (see Section 2.3.2.3).

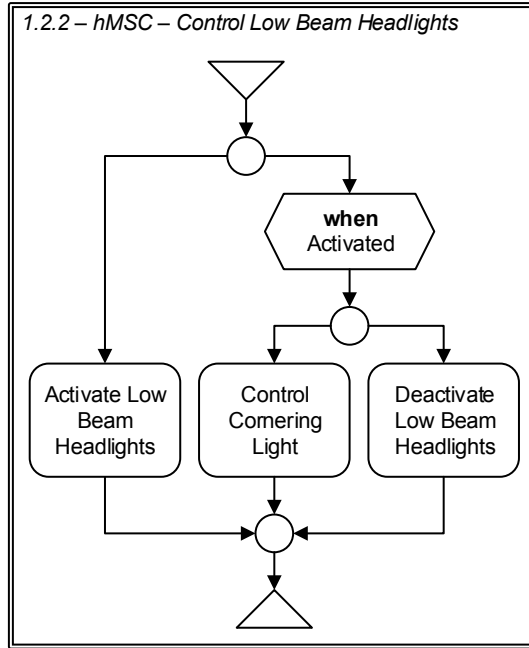

Figure 30: hMSC - Control Low Beam Headlights

#### 2.3.2.1 Activate Low Beam Headlights

The activation of the low beam headlights can be done by the ambient light, the daytime running light, manually, or automatically. Each activation ensures conditions without interdependencies to keep the low beam headlights active (cf. Section 2.3.2.2).

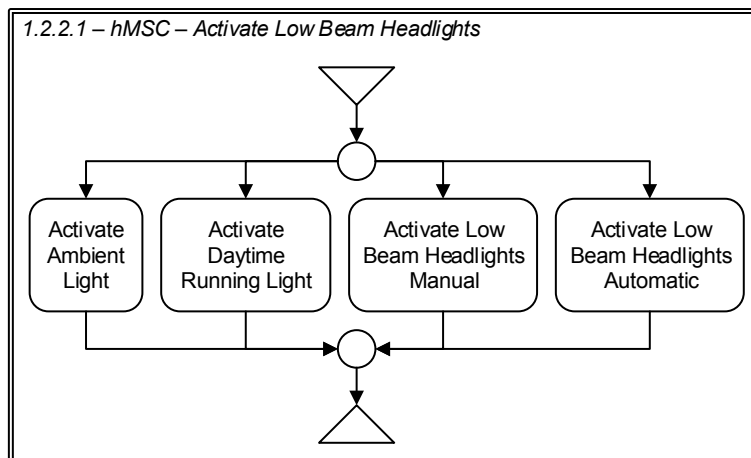

Figure 31: hMSC - Activate Low Beam Headlights

## Specification of the Behavioral Requirements

The activation of the ambient light needs the activation in the *Instrument Cluster* and the deactivation of the darkness mode in the *Darkness Switch* in armored vehicles (see Figure 32). In addition, the ambient light is not available with subvoltage, therefore the voltage gets checked. If the preconditions are given, there are two alternatives to activate the ambient light. As soon as at least one door of the vehicle is opened and the exterior brightness is lower than the threshold S1, the *Low Beam Headlight* sets the condition activated and ambient light on via door, and activates the low beam headlights via the *High Beam Module*. Otherwise the ambient light gets activated as soon as the engine is switched off and the ignition key is removed. In this case, the *Low Beam Headlight* sets the condition activated and ambient light on via Key, and activates the low beam headlights via the *High Beam Module*.

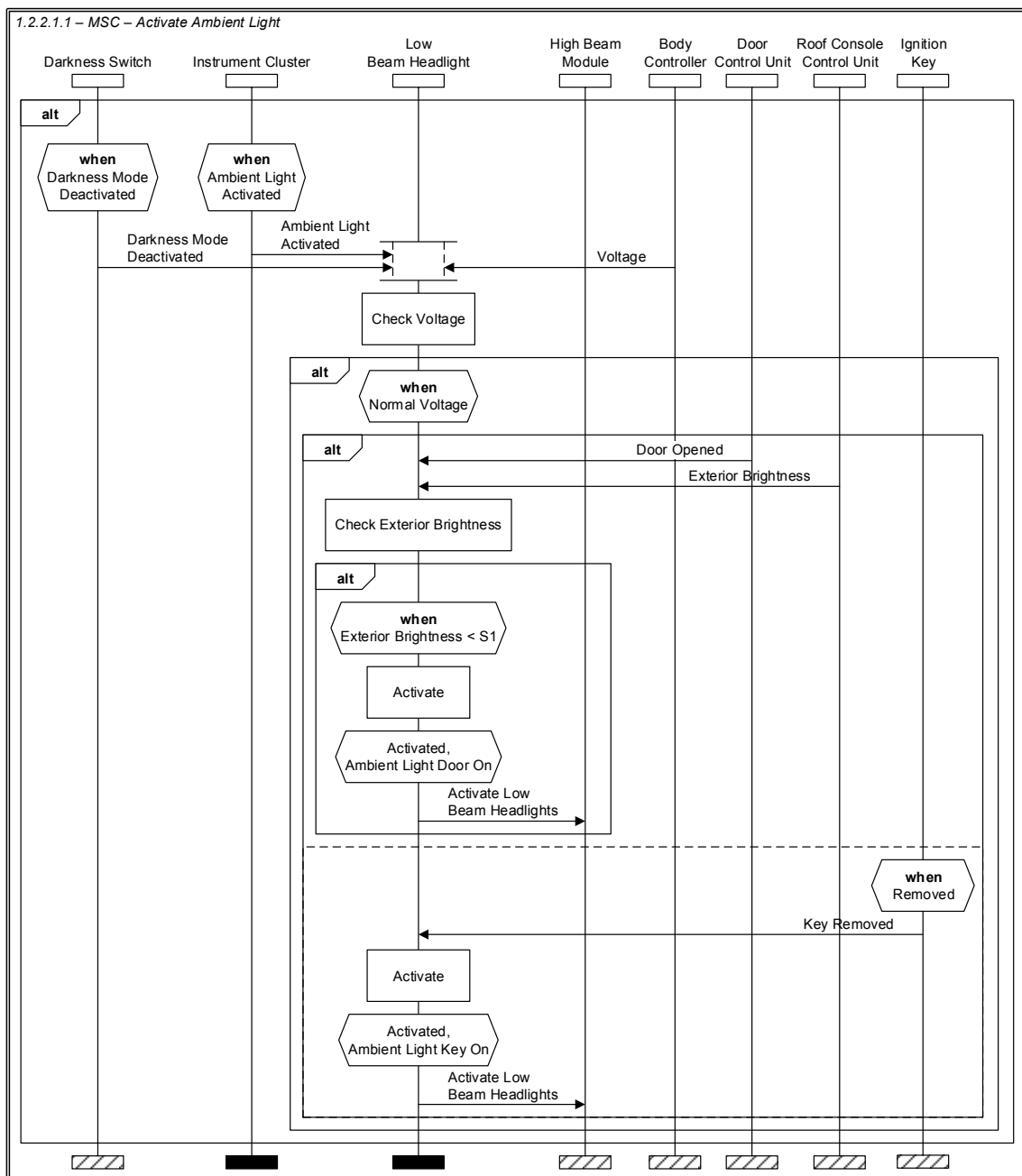

Figure 32: MSC - Activate Ambient Light

When the daytime running light is activated in the *Instrument Cluster* and the engine gets started, the *Low Beam Headlight* sets the condition to activated and daytime running light on, and activates the low beam headlights via the *High Beam Module* (see Figure 33).

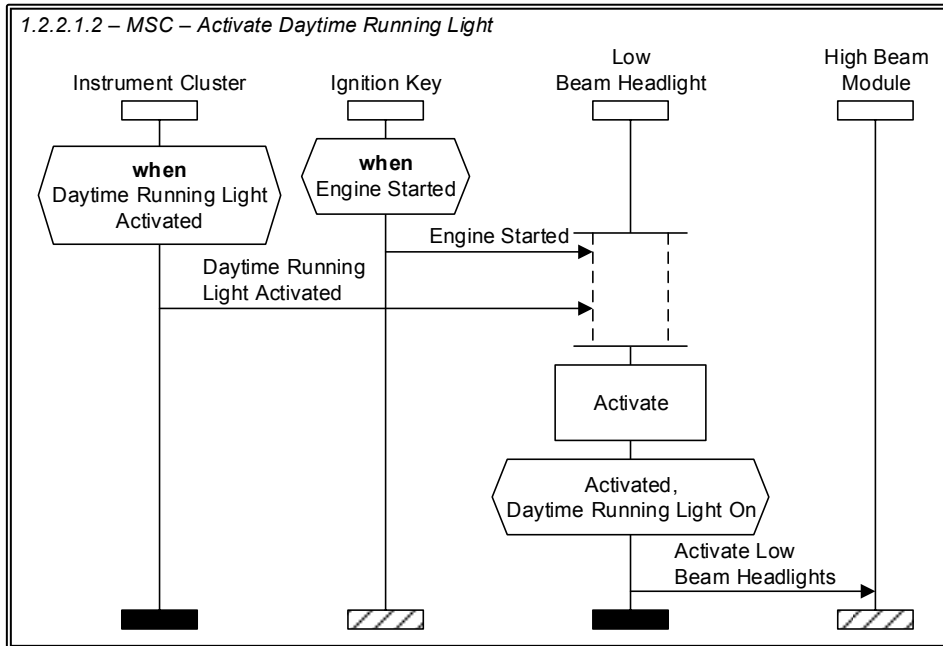

Figure 33: MSC - Activate Daytime Running Light

The manual activation of the low beam headlights is triggered when the exterior light is switched on in the *Rotary Light Switch* (see Figure 34). This leads to the setting conditions activated and manual on in the *Low Beam Headlight*, and the activation via the *High Beam Module*.

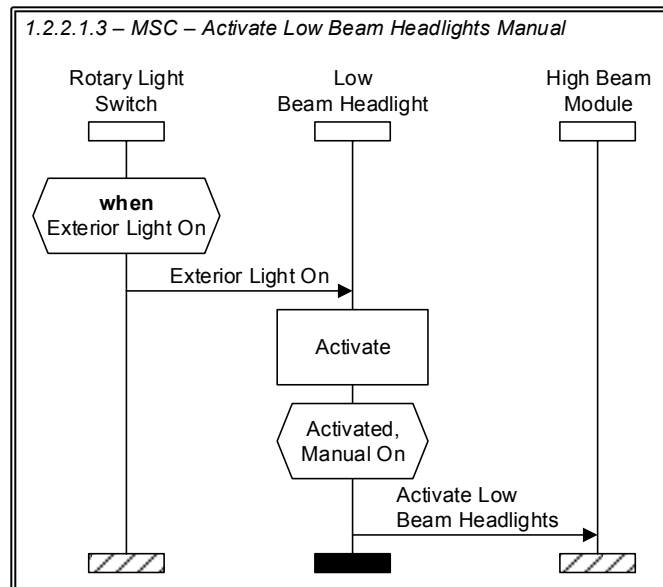

Figure 34: MSC - Activate Low Beam Headlights Manual

## Specification of the Behavioral Requirements

When the *Rotary Light Switch* is in auto mode and the darkness mode is deactivated (in armored vehicles), the exterior brightness is checked by the *Low Beam Headlight* (see Figure 35). If the exterior brightness is lower than the threshold  $S1$ , the *Low Beam Headlight* sets the condition to activated and automatic on, and activates the low beam headlights via the *High Beam Module*.

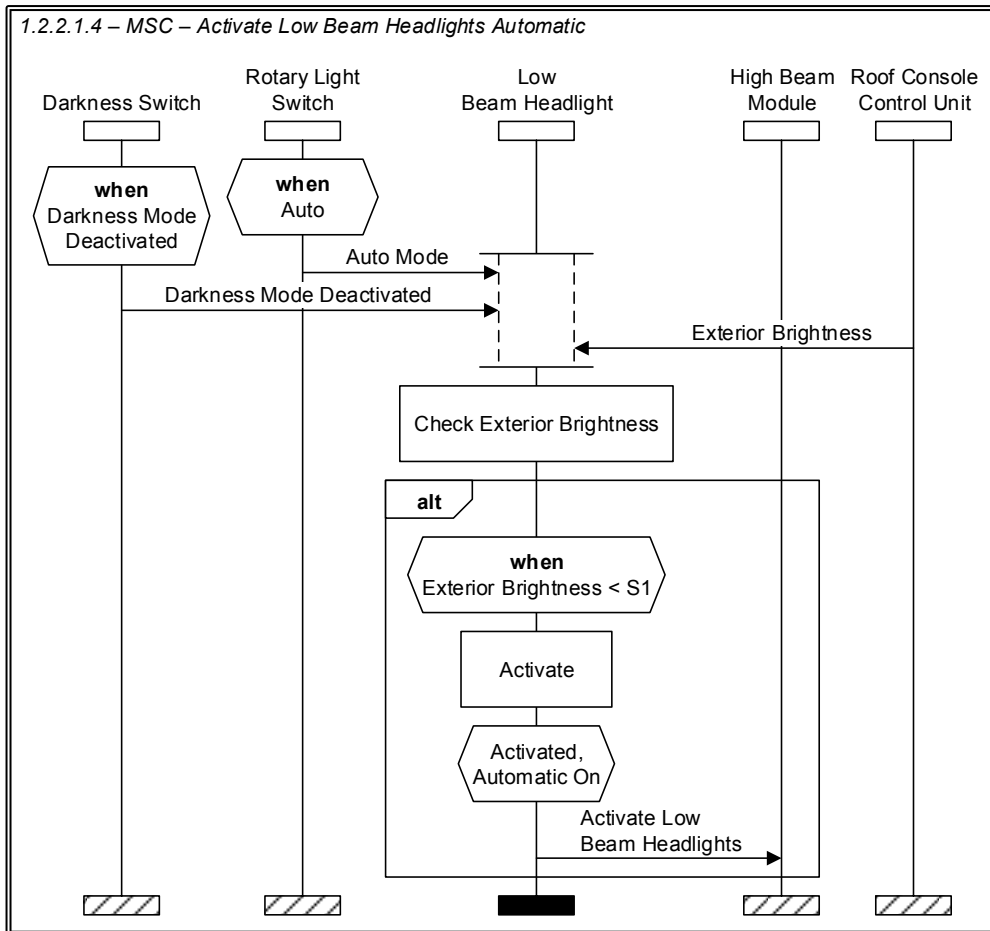

Figure 35: MSC - Activate Low Beam Headlights Automatic

### 2.3.2.2 Deactivate Low Beam Headlights

For the deactivation of the low beam headlights, none of the possible activation conditions must be enabled. Therefore, the four activation scenarios (cf. Section 2.3.2.1) need a deactivation scenario (see Figure 36). Every time a deactivation scenario was passed, the conditions are checked and the low beam headlights either remain activated or get deactivated.

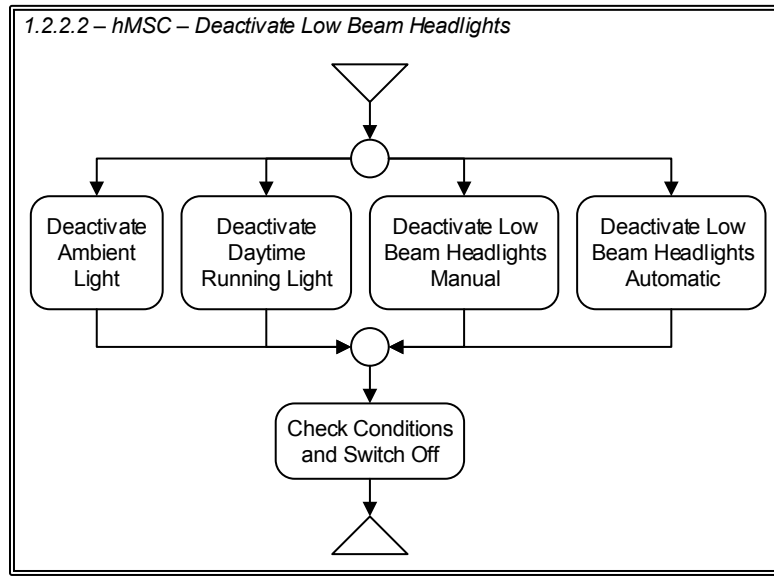

Figure 36: hMSC - Deactivate Low Beam Headlights

Figure 37 describes the four alternatives to deactivate the ambient light. In armored vehicles, the ambient light gets deactivated when the darkness mode is activated by the *Darkness Switch*. When the ambient light is deactivated in the *Instrument Cluster*, the *Low Beam Headlight* immediately deactivated both activation conditions. The third alternative only concerns the activation via door and is triggered by the *Door Control Unit* when all doors are closed. As long as the ambient light was activated by a key removal, the ambient light gets deactivated as soon as none of the actions open door, close door, insert or remove key occur within the next 30 seconds.



# Specification of the Behavioral Requirements

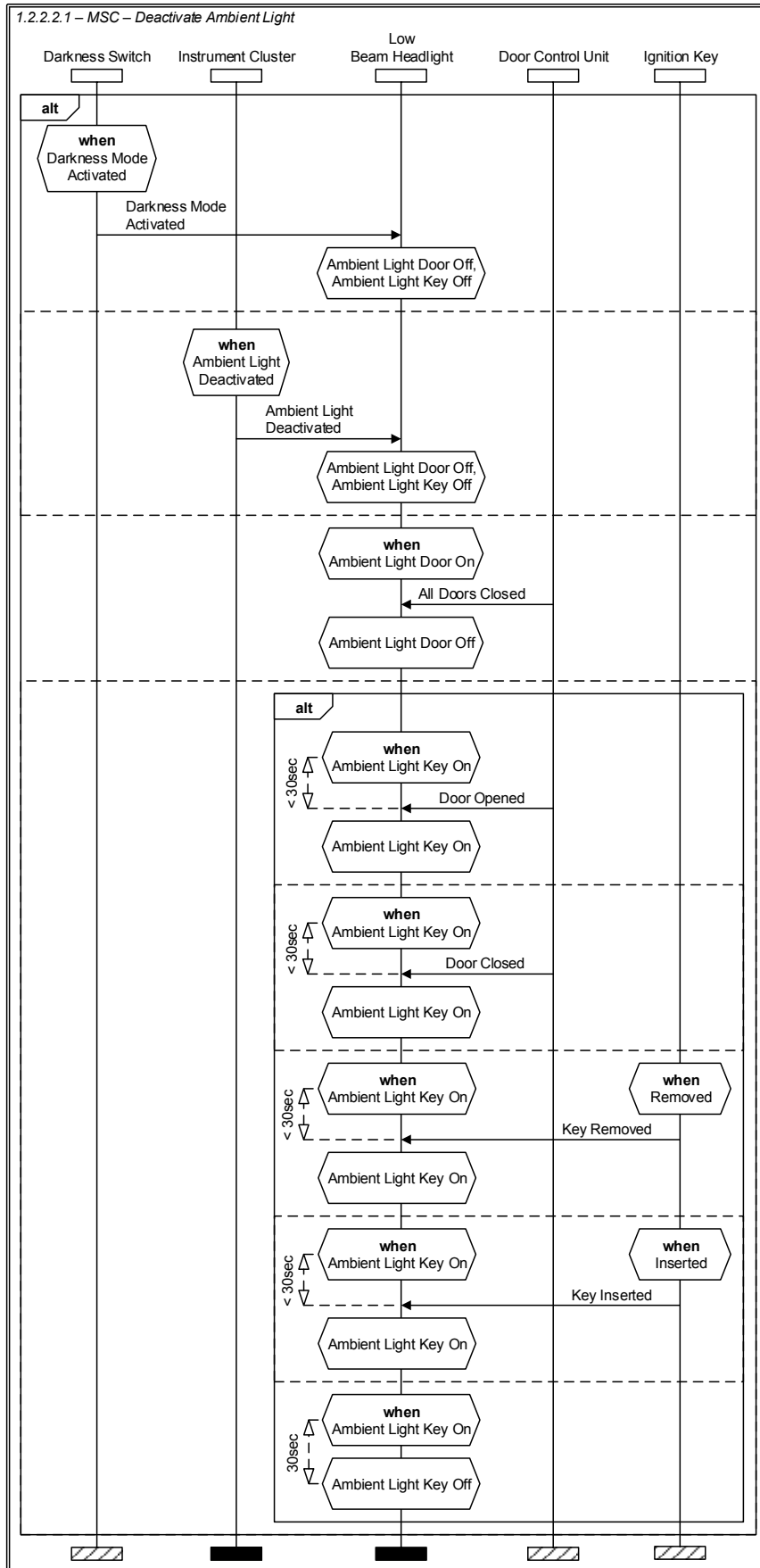

Figure 37: MSC - Deactivate Ambient Light

The daytime running light gets deactivated either by deactivating the function in the *Instrument Cluster* or by removing the *Ignition Key* (see Figure 38).

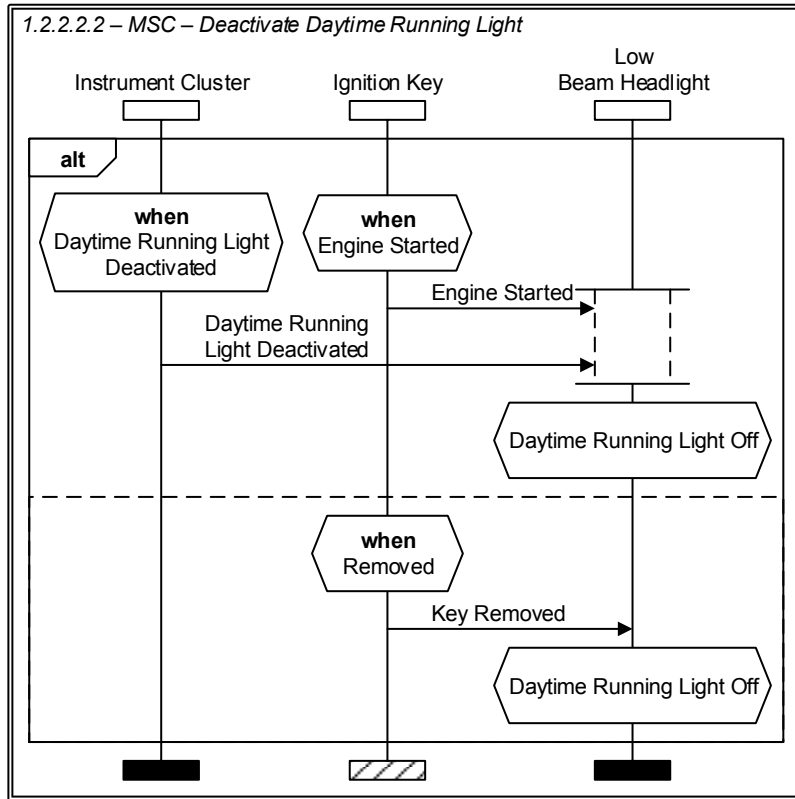

Figure 38: MSC - Deactivate Daytime Running Light

## Specification of the Behavioral Requirements

When the darkness mode gets activated in armored vehicles, the automatic condition of the *Low Beam Headlight* is set to off (see Figure 39). Otherwise the exterior brightness gets checked and the *Low Beam Headlight* deactivates the automatic condition 3 seconds after exceeding a threshold S2.

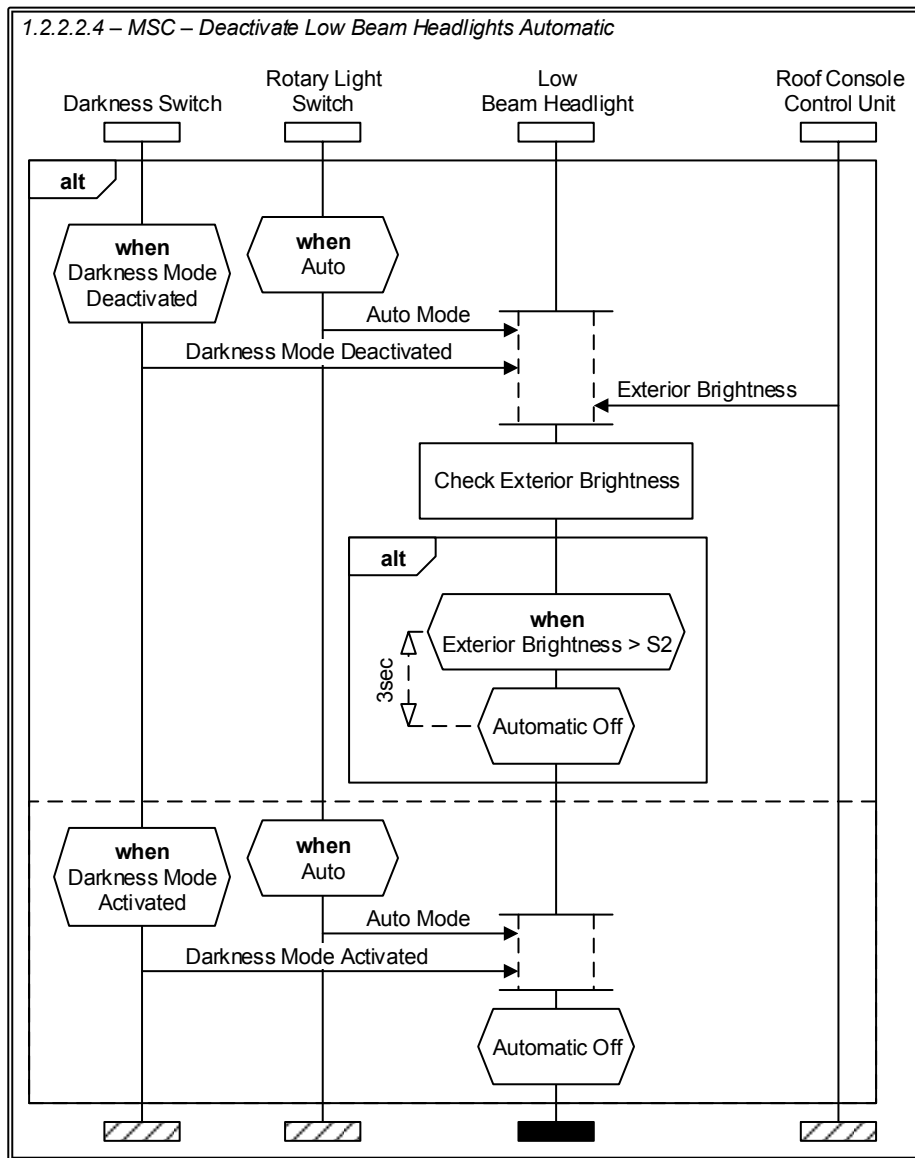

Figure 39: MSC - Deactivate Low Beam Headlights Automatic

To deactivate the low beam headlights manually, the driver needs to switch the *Rotary Light Switch* to off and the *Low Beam Headlight* is set to manual off (see Figure 40).

When one of the activation conditions of the low beam headlight was deactivated the conditions are checked, and only if all conditions are set to off, the *Low Beam Headlight* is set to deactivated and the low beam headlights get deactivated via the *High Beam Module* (see Figure 41).

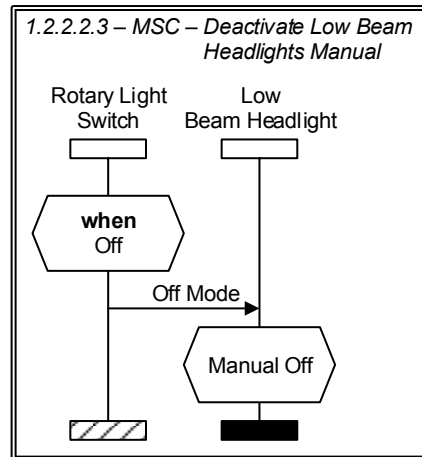

Figure 40: MSC - Deactivate Low Beam Headlights Manual

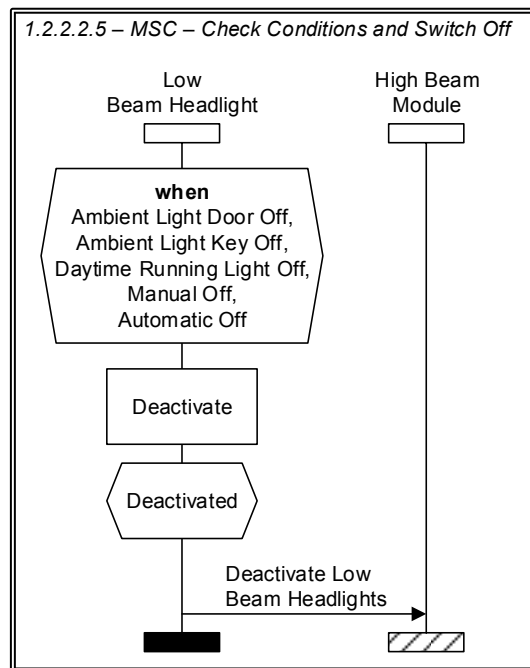

Figure 41: MSC - Check Conditions and Switch Off

### 2.3.2.3 Control Cornering Light

When the darkness mode is deactivated and direction blinking is requested by the *Turning Light*, the cornering light is activated by the *Low Beam Headlight* via the *Body Controller* if the vehicle drives slower than 10 km/h and there is no subvoltage (see Figure 42). If no more blinking is requested for 10 seconds the cornering light gets deactivated.

# Specification of the Behavioral Requirements

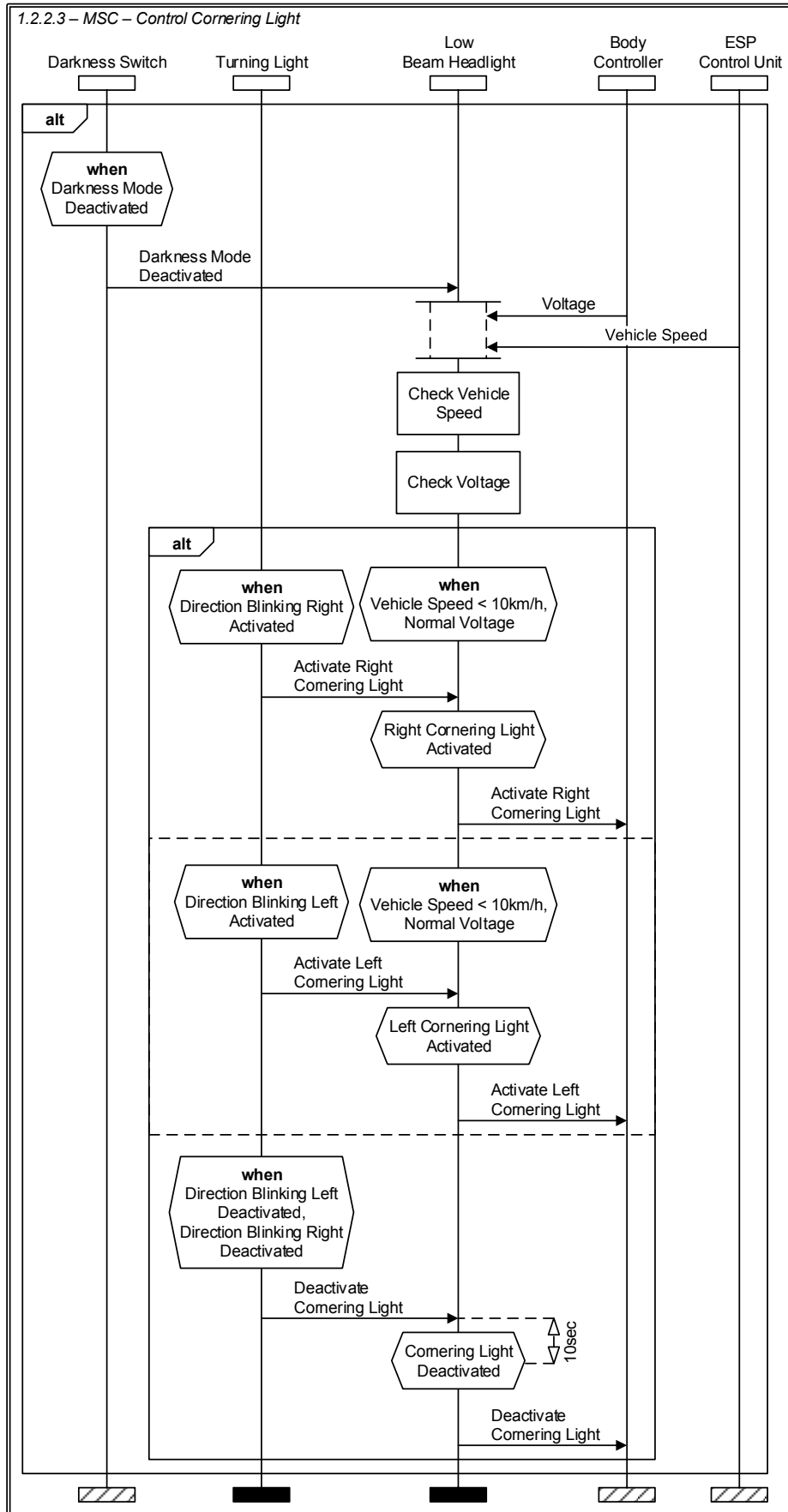

Figure 42: MSC - Control Cornering Light

### 2.3.3 Handle Overvoltage

To protect the illuminants from burning out in case of an occurring overvoltage, the *Adaptive High Beam Headlight* and the *Low Beam Headlight* must adapt the pulse width via the *High Beam Module* and the *Body Controller* (see Figure 43).

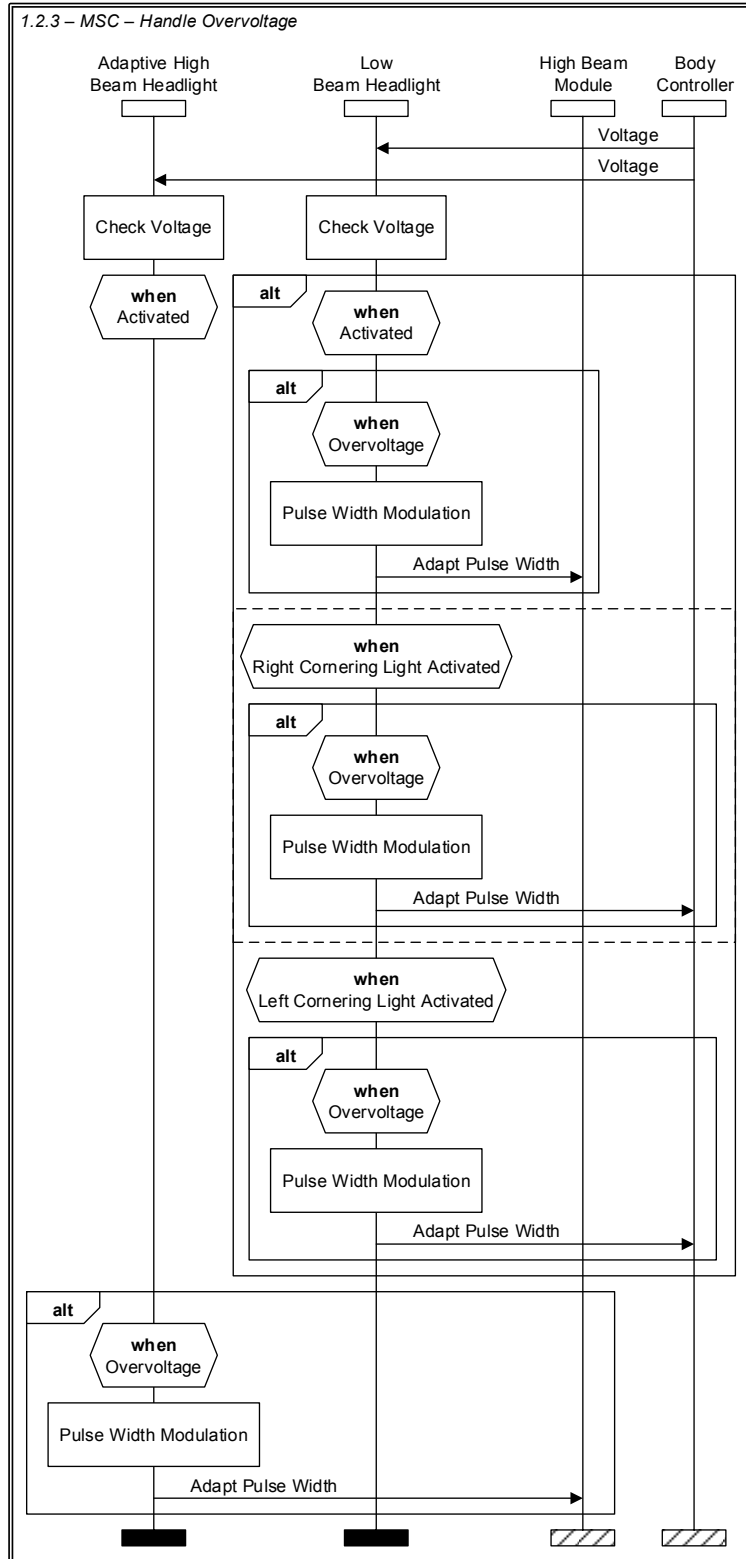

Figure 43: MSC - Handle Overvoltage

## 2.4 Control Turn Signal

The control of the turn signal (see Figure 44) comprises the activation and deactivation of the direction and tip blinking, and the control of the hazard warning light (see Section 2.4.3). The direction and tip blinking need to be differentiated between blinking left (see Section 2.4.1) or right (see Section 2.4.2). To activate one of the blinking directions, the other blinking direction must be deactivated. This represents the vertical neutral position of the pitman arm (cf. Section 2.2.2). However, controlling the hazard warning switch is independent from the actual blinking status.

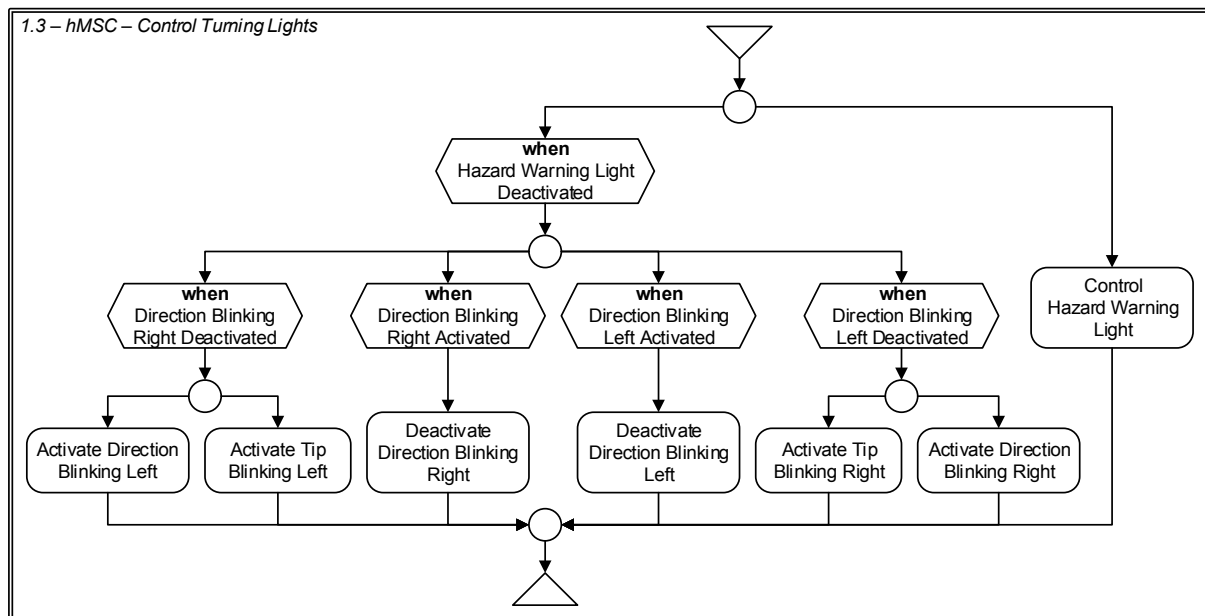

Figure 44: hMSC - Control Turning Lights

### 2.4.1 Direction Blinking Left

The activation of the left direction blinking is triggered by the *Pitman Arm* position (engaged) down (see Figure 45). This leads to the activation of the left direction indicators by the *Turning Light* via the *Body Controller* and the *Door Control Unit* with a pulse ratio bright to dark 1:1.

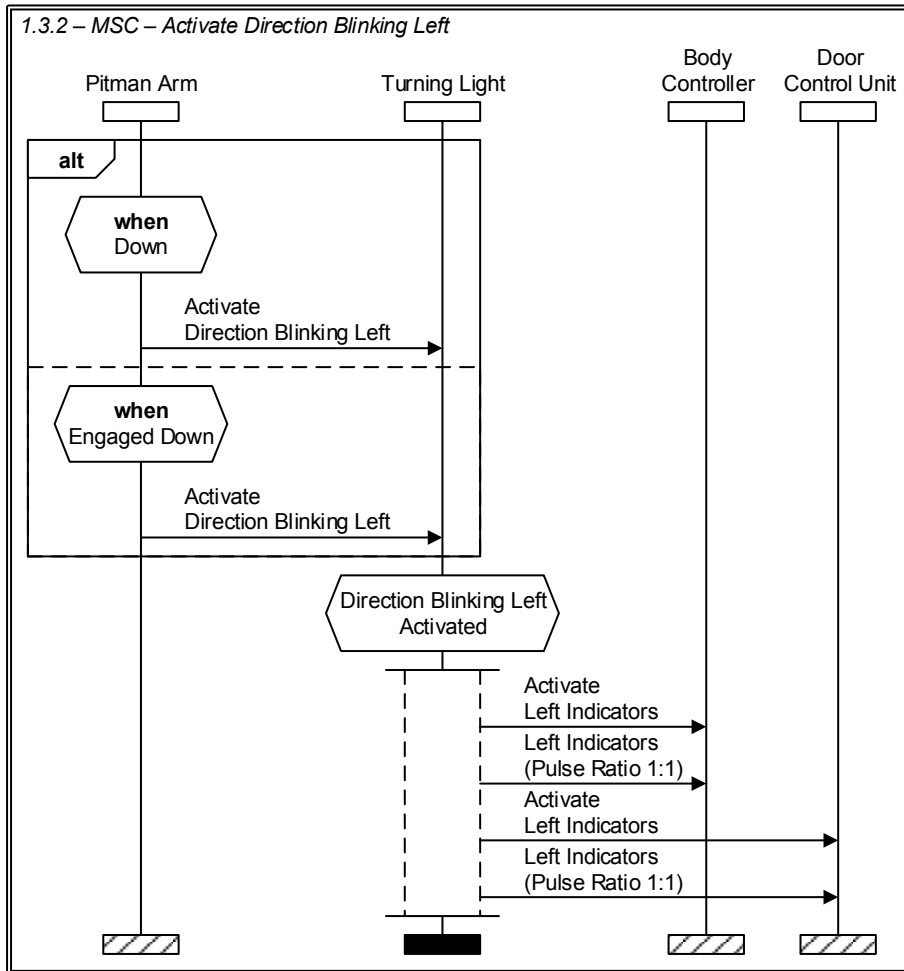

Figure 45: MSC - Activate Direction Blinking Left



## Specification of the Behavioral Requirements

When the Pitman Arm position is moved to down for less than 0.5 seconds, the left tip blinking is activated (see Figure 46). The activation of tip blinking in the *Turning Light* leads to an activation of the left direction indicators for three flashing cycles.

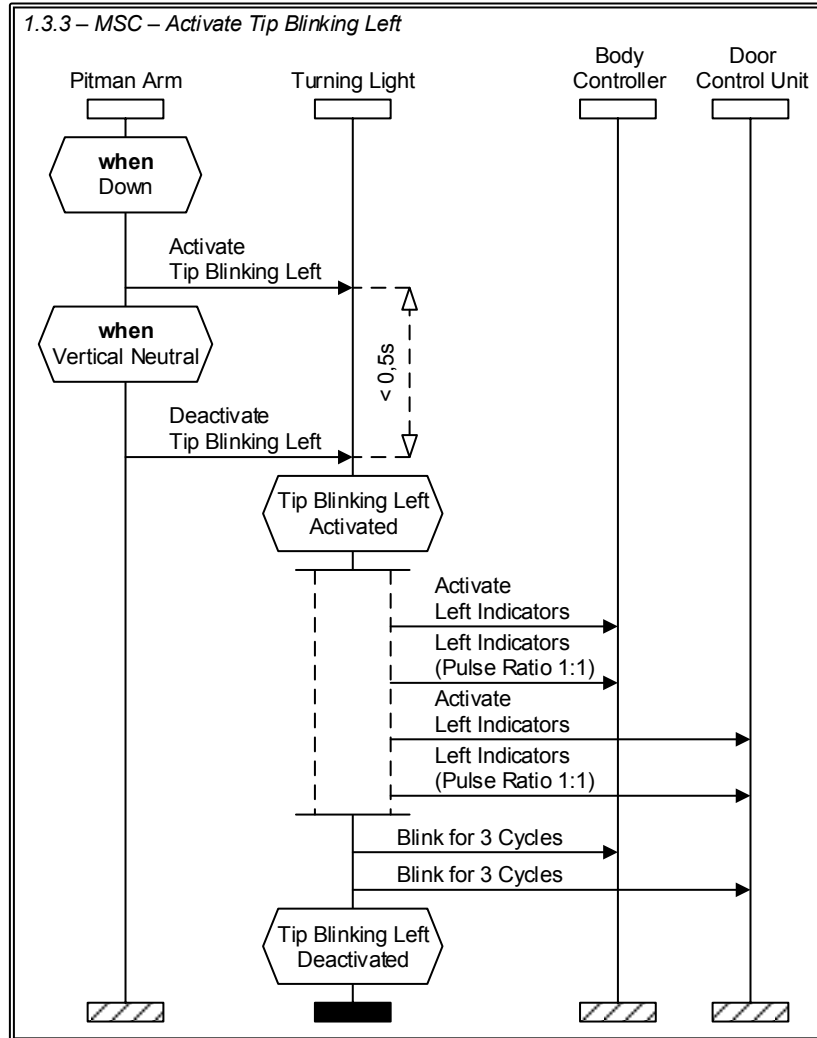

Figure 46: MSC - Activate Tip Blinking Left

To deactivate the left direction blinking, the *Pitman Arm* needs to be moved to the vertical neutral position (see Figure 47). The *Turning Light* switches its state to direction blinking left deactivated and deactivates the left direction indicators via the *Body Controller* and the *Door Control Unit*.

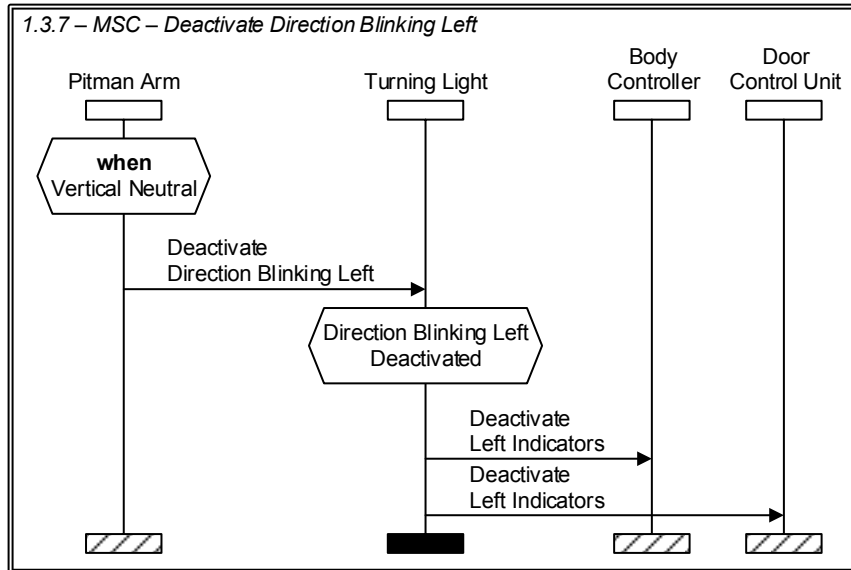

Figure 47: MSC - Deactivate Direction Blinking Left

### 2.4.2 Direction Blinking Right

The right direction and tip blinking is analogous to the left side (compare Figure 48 with Figure 45, Figure 50 with Figure 46, and Figure 49 with Figure 47).

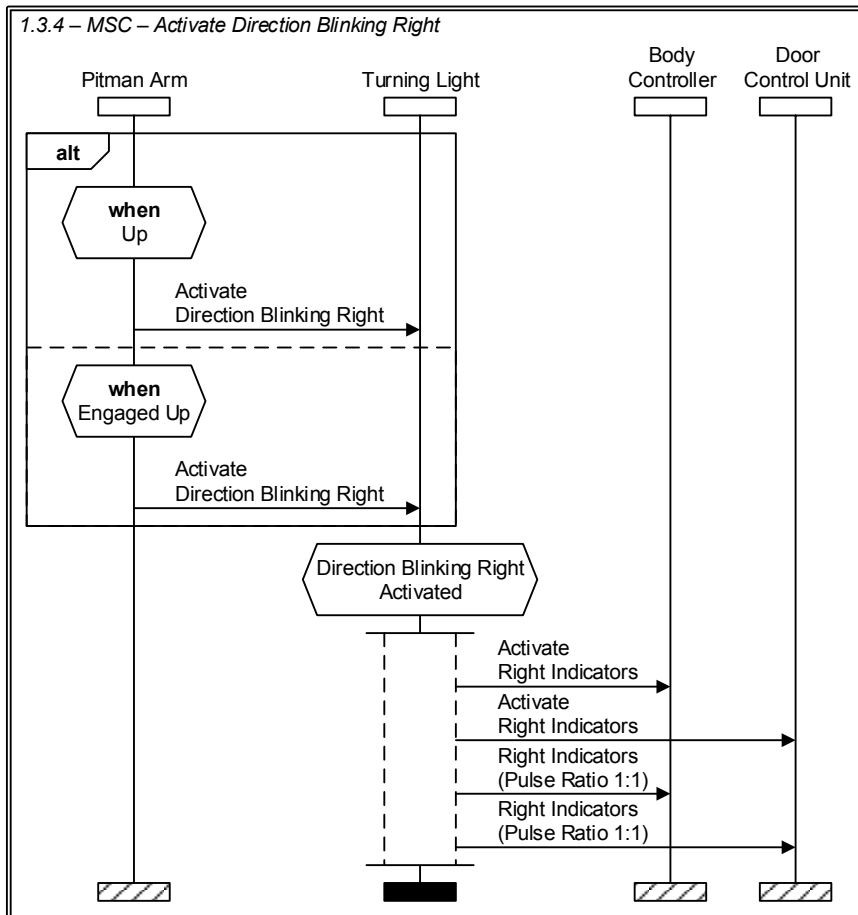

Figure 48: MSC - Activate Direction Blinking Right

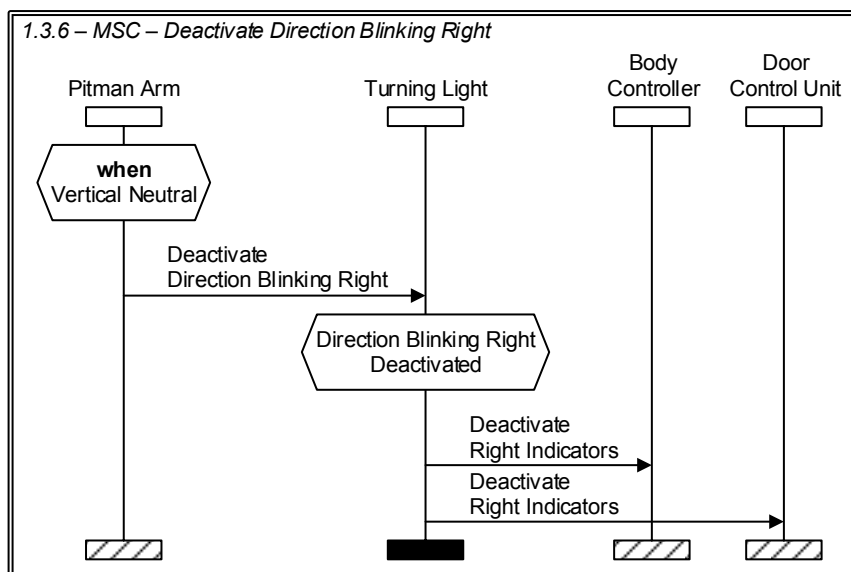

Figure 49: MSC - Deactivate Direction Blinking Right

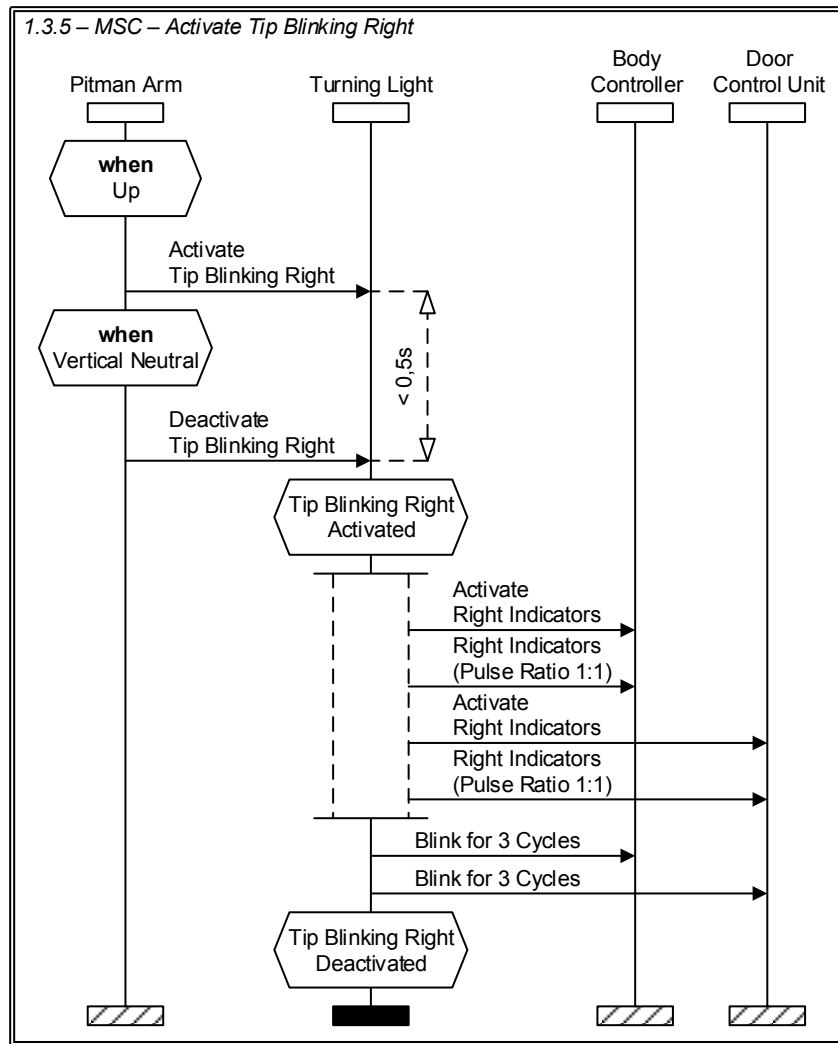

Figure 50: MSC - Activate Tip Blinking Right

### 2.4.3 Hazard Warning Light

When the hazard warning light gets activated via the *Hazard Warning Light Switch*, the *Turning Light* activates both (left and right) direction indicators via the *Body Controller* and the *Door Control Unit* (see Figure 51). For energy saving reasons, the pulse ratio is reduced (bright to dark 1:2) when the *Ignition Key* is removed. To deactivate the hazard warning light, the *Hazard Warning Light Switch* must be switched off. The *Turning Light* sets its condition back to hazard warning light deactivated and direction blinking will be continued - if activated (cf. Figure 44).

# Specification of the Behavioral Requirements

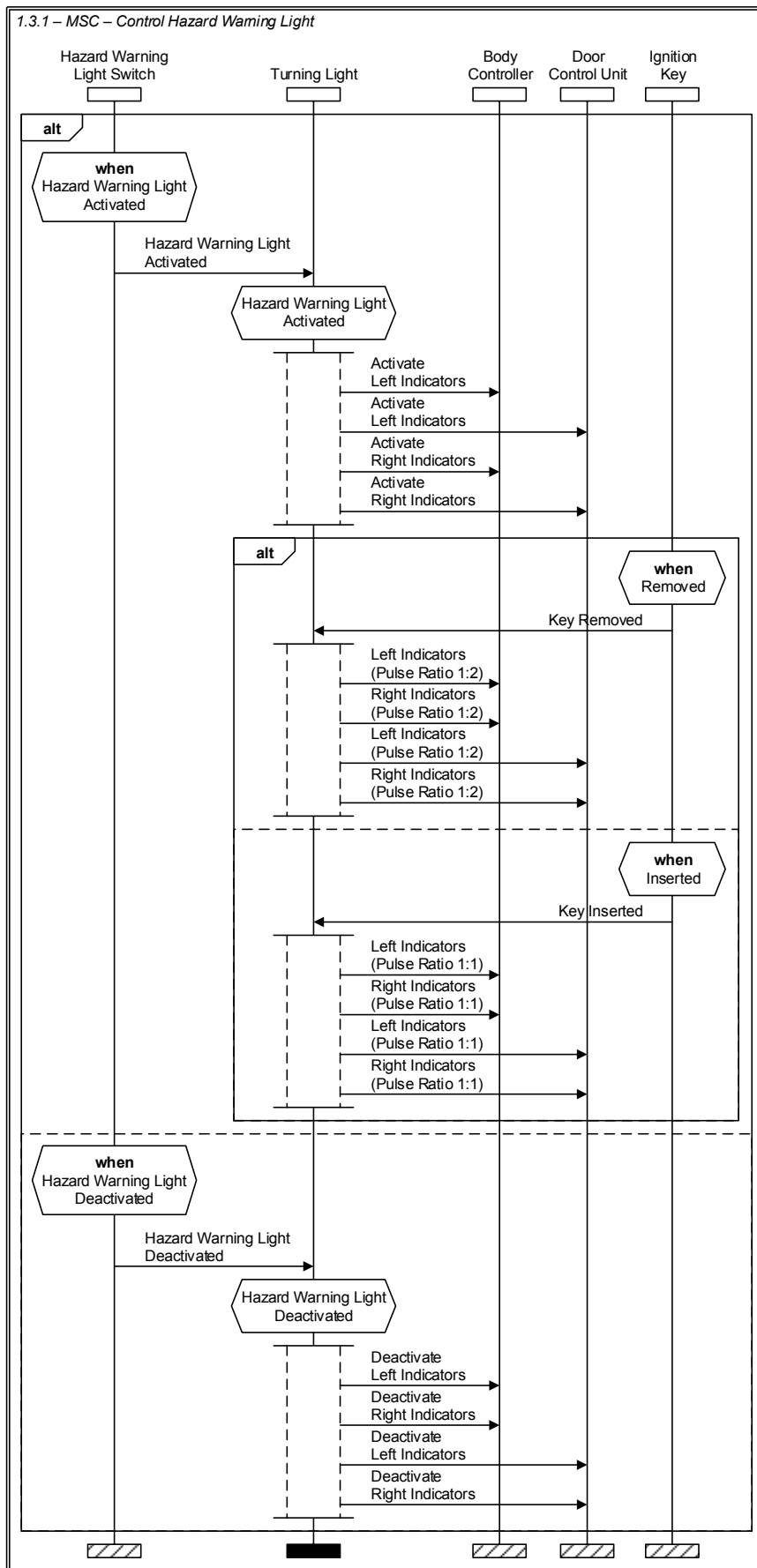

Figure 51: MSC - Control Hazard Warning Light

## 2.5 Detect Faults

In addition to the handling of over- and subvoltage (e.g., Section 2.3.3), the system provides the functionality to detect defective headlights (see Figure 52). The *High Beam Module*, the *Body Controller* and the *Door Control Unit* transmit the illuminant status to the *Defect Detection*, which checks the status and informs the *Instrument Cluster* about defective illuminants. Finally, the *Instrument Cluster* prioritizes the displayed information.

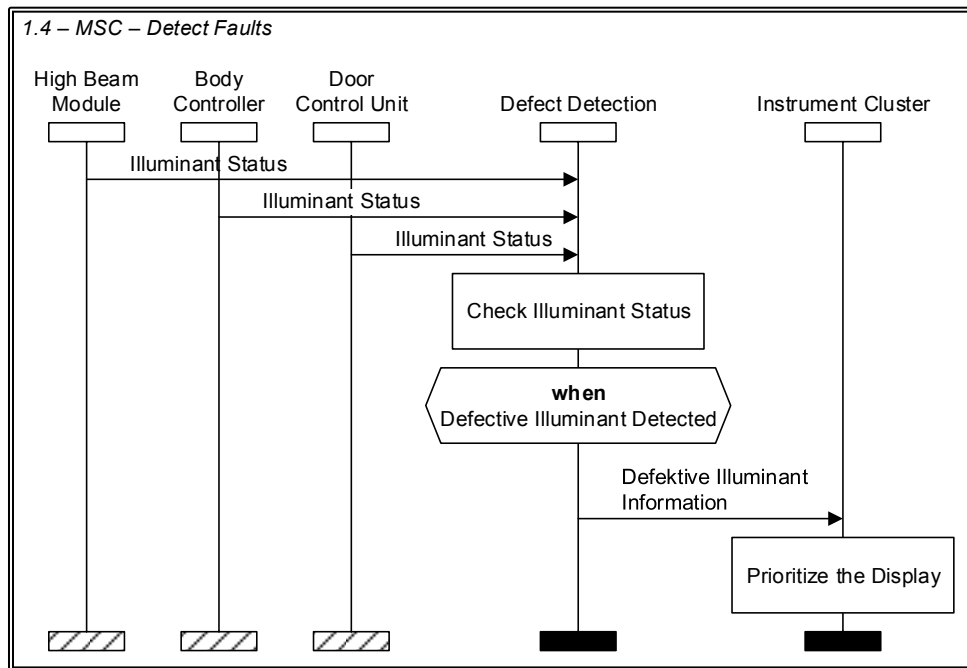

Figure 52: MSC - Detect Faults

### 3 Specification of the Functional Design

The model-based specification of a first functional design – as described in the following – comprises the combination of function networks and interface automata. The interaction between system functions and context functions is described by function network diagrams. Additionally, the internal behavior of the system functions is specified as interface automata. The context of the system and the interaction of the main system functions are described in Section 3.1, while the detailed descriptions of the main system functions are presented in Section 3.2, 3.3, and 3.4.

The specified functions of the ELS are subdivided into system and context functions. An overview is given in Table 2 and Table 3.

**Table 2: Context Functions**

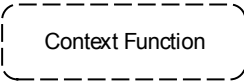
Context Function	Shapes
High Beam Module	
Body Controller	
Use Ignition Key	
Measure Exterior Brightness	
ESP Control	
Turn Rotary Light Switch	
Set Instrument Cluster	
Door Control	
Move Pitman Arm	
Detect Vehicles	
Switch Darkness Mode	
Switch Hazard Warning Light	

**Table 3: System Functions**

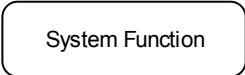
System Function	Level	Shapes
Control Adaptive Exterior Lighting System	0	
Control Headlights	1	
Control High Beam Headlights	2	
Activate Manual High Beam Headlights	3	
Activate Adaptive High Beam Headlights	3	
Deactivate Adaptive High Beam Headlights	3	
Check Voltage	3	
Adapt High Beam Headlights	3	
Control Low Beam Headlights	2	
Activate Low Beam Headlights	3	
Activate Low Beam Headlights Manual	4	
Activate Low Beam Headlights Automatic	4	
Activate Daytime Running Light	4	
Activate Ambient Light	4	
Check Conditions	5	
Activate by Door	5	
Activate by Key	5	
Deactivate Low Beam Headlights	3	
Deactivate Low Beam Headlights Manual	4	
Deactivate Low Beam Headlights Automatic	4	
Deactivate Daytime Running Light	4	
Deactivate Ambient Light	4	
Check Conditions and Switch Off	4	
Control Cornering Light	3	
Check Conditions	4	
Activate Left Cornering Light	4	
Deactivate Left Cornering Light	4	
Activate Right Cornering Light	4	
Deactivate Rights Cornering Light	4	
Handle Overvoltage	2	
Control Turn Lights	1	



Specification of the Functional Design

Activate Hazard Warning Light	2	
Deactivate Hazard Warning Light	2	
Activate Direction Blinking Left	2	
Activate Tip Blinking Left	2	
Deactivate Direction Blinking Left	2	
Activate Direction Blinking Right	2	
Activate Tip Blinking Right	2	
Deactivate Direction Blinking Right	2	
Detect Faults	1	

### 3.1 Structure of the Functional Design

The Adaptive Exterior Lighting System comprises three main system functions *Control Headlights*, *Control Turn Lights*, and *Detect Faults*, which are represented by the abstract system function *Control Adaptive Exterior Lighting System*. The context of this abstract system function is described in a context diagram (cf. Figure 53). As modeled in the context diagram, the abstract system function interacts with the 12 context functions and interchanges 58 messages. For reasons of clarity and comprehensibility, several messages are summarized and labeled with an expression (e. g., the message *Key {Inserted | Removed}* represents the messages *Key Inserted* and *Key Removed*). However, condensed messages are separated on lower abstraction levels.

In the following, the meaning of all interactions between functions is usually described on the lowest abstraction level where no subdivision of functions occurs.

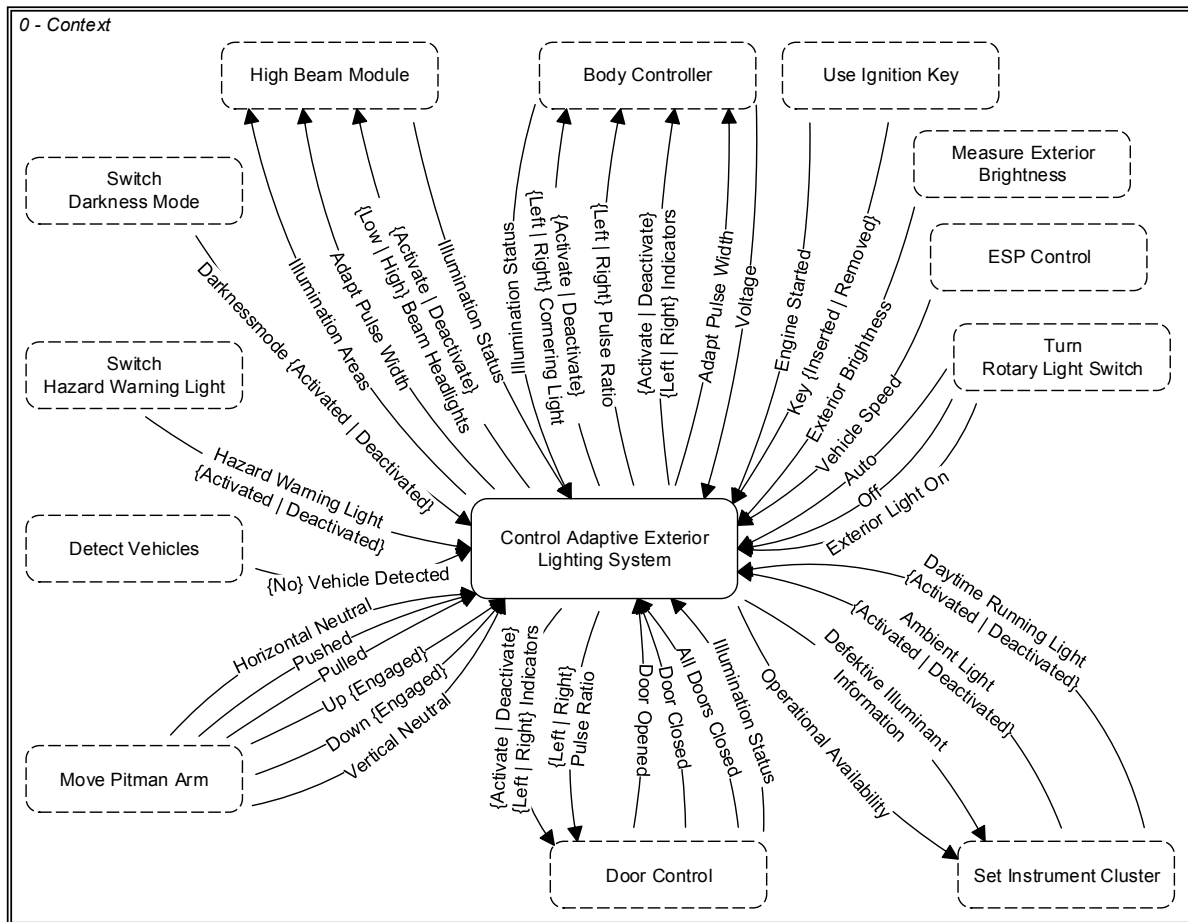
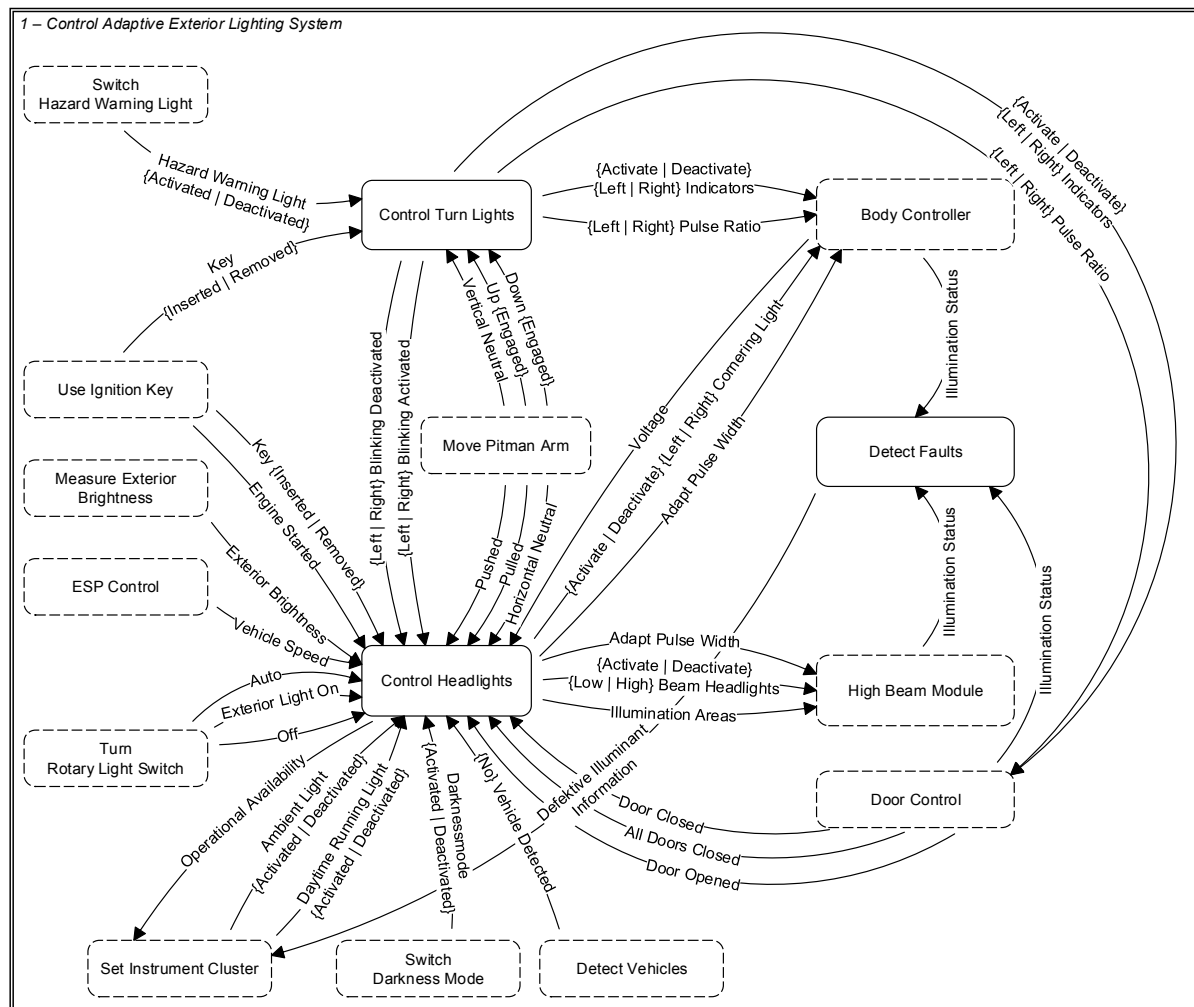

Figure 53: Context Diagram

## Specification of the Functional Design

The three main system functions *Control Headlights*, *Control Turn Lights*, and *Detect Faults* and their message interchanges are presented in Figure 54. In contrast to the context diagram, it is already noticeable how the messages between system functions and context functions are distributed on this level of abstraction. The messages for the activation and deactivation of the hazard warning light are only connected to the system function *Control Turn Lights*, for example. Moreover, the system function *Control Turn Lights* informs the system function *Control Headlight* about the status of the direction blinking.



**Figure 54: Function Network Diagram – Control Adaptive Exterior Lighting System**

In the following sections, the three main system function *Control Headlights* (Section 3.2), *Control Turn Lights* (Section 3.3) and *Detect Faults* (Section 3.4) with their interactions and internal behavior are described in detail.

### 3.2 Control Headlights

The control of the headlights (cf. Figure 55) is subdivided into the three system functions *Control High Beam Headlights* (cf. Section 3.2.1), *Control Low Beam Headlights* (cf. Section 3.2.2), and *Handle Overvoltage* (cf. Section 3.2.3). The control of the high beam headlights is triggered by the horizontal position of the pitman arm, the detection of vehicles, the vehicle speed, the position of the rotary light switch, and the voltage. Moreover, the activation and deactivation as well as the illumination areas of the high beam headlights are transmitted to the context function *High Beam Module*. To control the low beam headlights and the cornering light, the ambient and daytime running light settings, the vehicle speed, the position of the rotary light switch, the voltage, the exterior brightness, the status of the darkness mode and the doors as well as the information about the ignition key are used. Moreover, the status of the direction blinking from the system function *Control Turn Lights* (cf. Section 3.3) is required for the cornering light functionality. The system function *Handle Overvoltage* needs to get enabled by the system function *Control High Beam Headlights* or *Control Low Beam Headlights*.

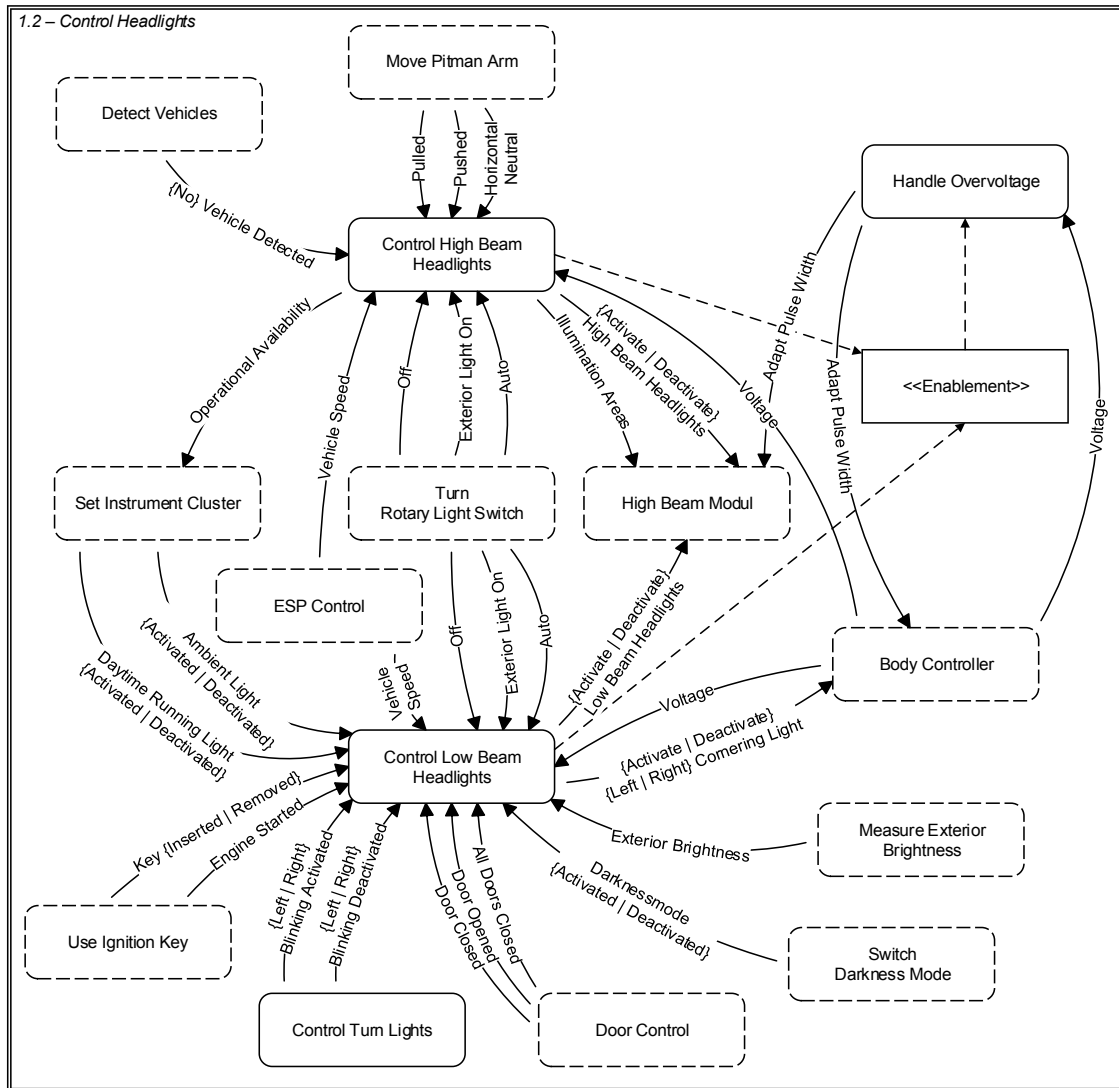

Figure 55: Function Network Diagram - Control Headlights

### 3.2.1 Control High Beam Headlights

The system function *Control High Beam Headlights* (see Figure 56) is subdivided into the system functions *Activate Manual High Beam Headlights* and *Activate Adaptive High Beam Headlights* (see Section 3.2.1.1), *Deactivate High Beam Headlights* (see Section 3.2.1.2), and *Check Voltage* and *Adapt High Beam Headlights* (see Section 3.2.1.3).

By modeling the dependencies between the system functions, it is visible that the system function *Adapt High Beam Headlights* needs to be enabled by the system function *Check Voltage*. In addition, the system functions *Check Voltage* and *Deactivate High Beam Headlights* need the enablement by the system functions *Activate Manual High Beam Headlights* or *Activate Adaptive High Beam Headlights*. Otherwise, the system function *Deactivate High Beam Headlights* enables the system functions *Activate Manual High Beam Headlights* and *Activate Adaptive High Beam Headlights*.

As an interaction between the system functions, the status of the adaption is transmitted from *Activate Adaptive High Beam Headlights* and *Deactivate High Beam Headlights* to *Check Voltage* and as a result to *Adapt High Beam Headlights*. The other interactions between context and system functions are described as referred to in Figure 56 in the following.

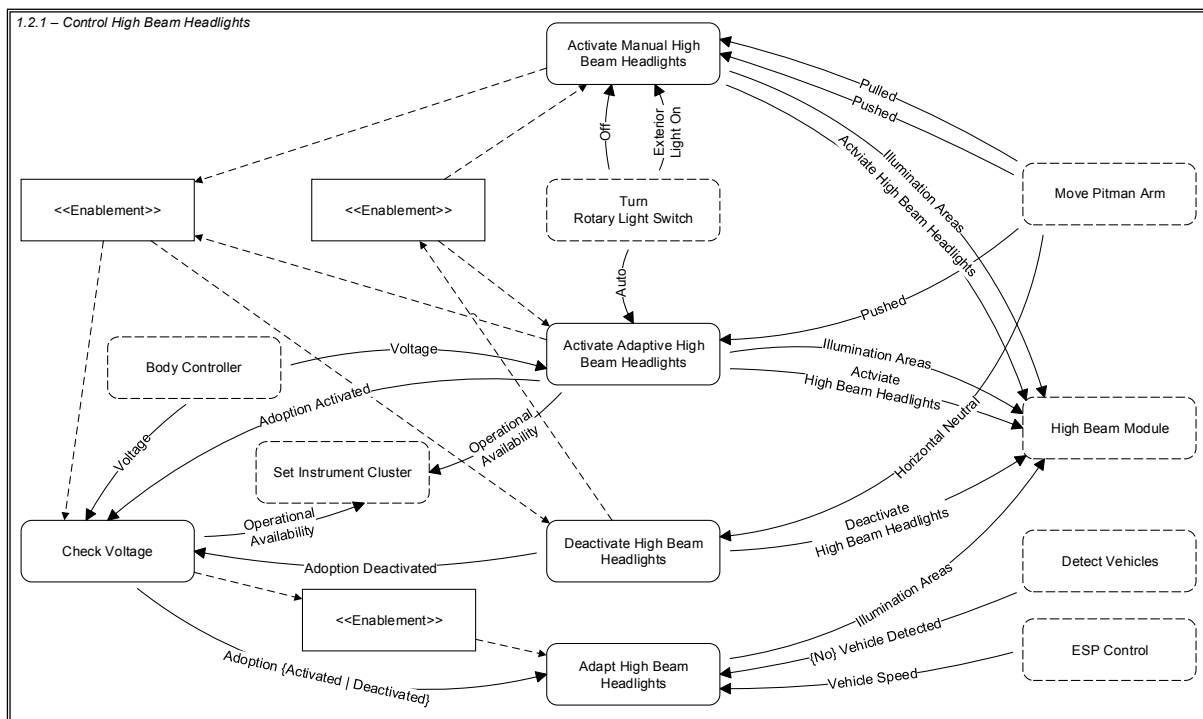

Figure 56: Function Network Diagram - Control High Beam Headlights

### 3.2.1.1 Activate High Beam Headlights

When the high beam headlights are activated by the context functions *Move Pitman Arm* and *Turn Rotary Light Switch*, the messages with fixed *Illumination Areas* of 220m and *Activate High Beam Headlights* are transmitted to the context function *High Beam Module* (Figure 57). The activation by the pitman arm includes the so-called flasher (cf. Section 2.2.2).

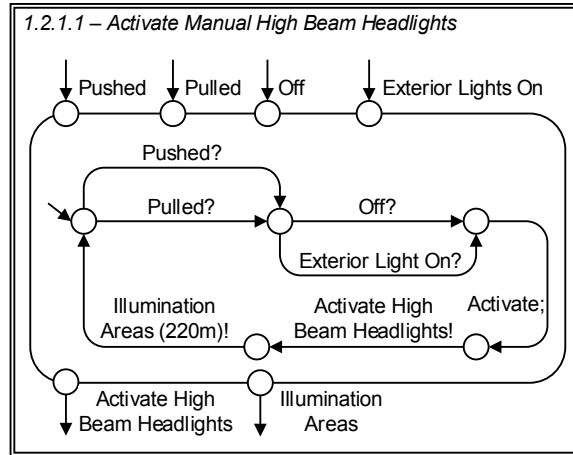

Figure 57: Interface Automaton - Activate Manual High Beam Headlights

The activation of the adaptive high beam headlight is initialized by the pushed position of the pitman arm and the auto mode of the rotary light switch (see Figure 58). After activating the high beam headlights by the message *Activate High Beam Headlights*, transmitted to the context function *High Beam Module*, the voltage needs to be checked. The adaption of the high beam headlights is not available with subvoltage and the illumination area is set to default. Otherwise the adaption is activated and the *Operational Availability* of the adaptive high beam headlight is indicated by a symbol in the instrument cluster.

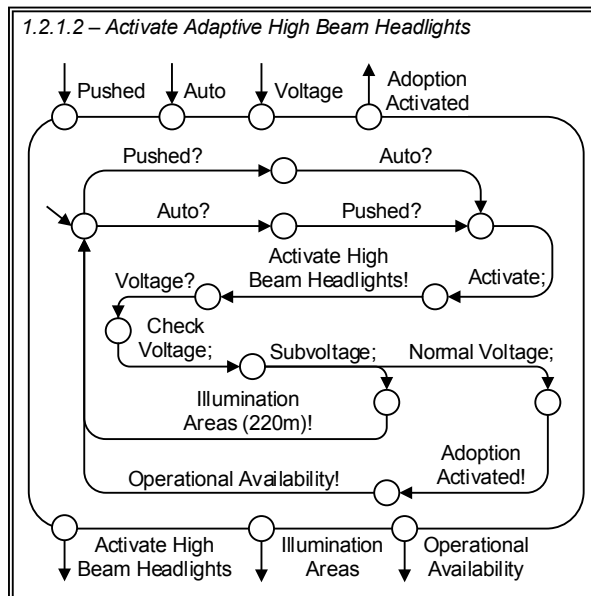

Figure 58: Interface Automaton - Activate Adaptive High Beam Headlights

### 3.2.1.2 Deactivate High Beam Headlights

When the pitman arm is moved again in the horizontal neutral position, the *Adaptive High Beam Headlight* is deactivated immediately (see Figure 59). Furthermore, the adaption is deactivated (if necessary) and the operational availability is updated in the instrument cluster.

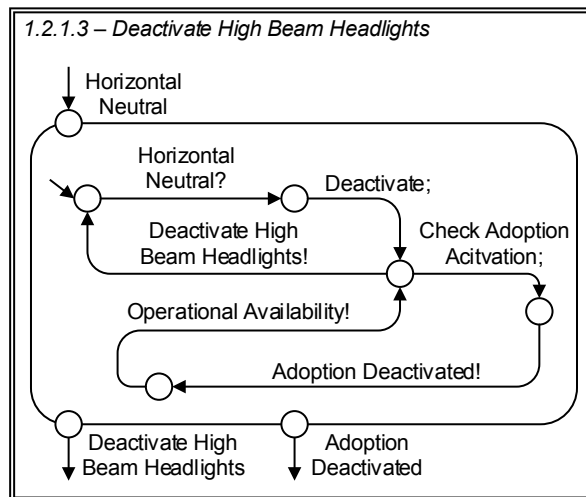

Figure 59: Interface Automaton - Deactivate High Beam Headlights

### 3.2.1.3 Check Voltage and Adapt High Beam Headlights

Before the high beam headlight gets adapted, the voltage needs to be checked again (see Figure 60, cf. Figure 58).

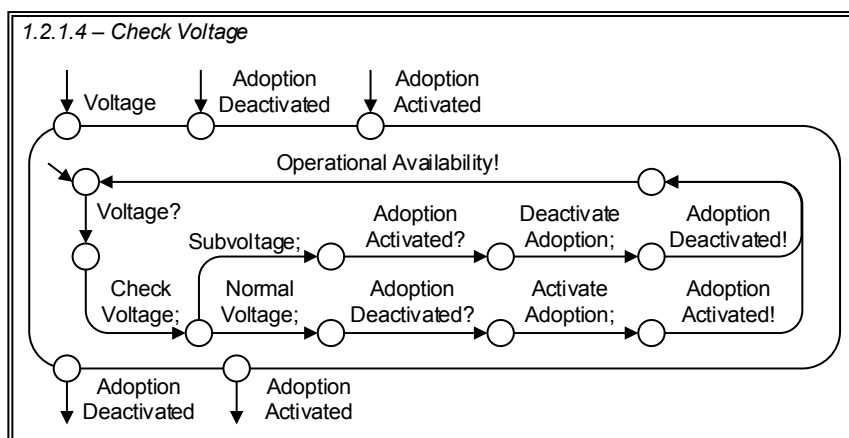

Figure 60: Interface Automaton - Check Voltage

When the adaption is activated and the context function *Detect Vehicles* recognizes the lights of an advancing vehicle, the activated high beam headlights are reduced to low beam headlights by reducing the illumination area to 65m in the context function *High Beam Module*. If no advancing vehicle is recognized any more, the high beam illumination is restored and the illumination area is calculated within 100m and 300m, depending on the vehicle speed. Otherwise, when the adoption is deactivated, the illumination areas are set to default 220m.

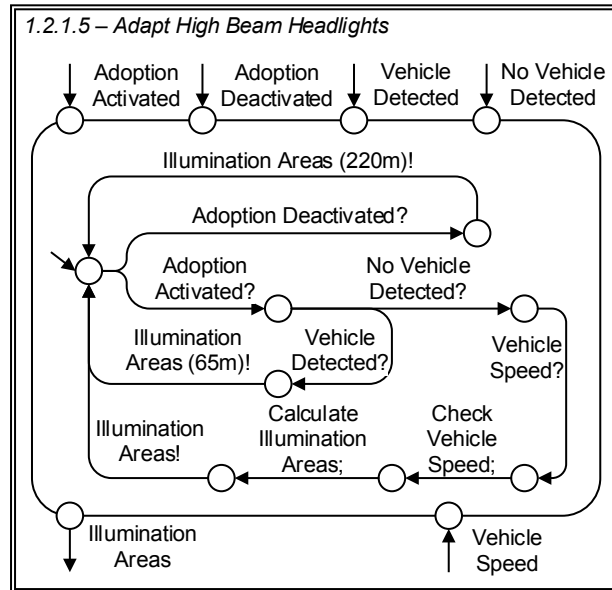

Figure 61: Interface Automaton - Adapt High Beam Headlights



### 3.2.2 Control Low Beam Headlights

In Figure 62, the subdivision of the system function *Control Low Beam Headlights* by introducing the system functions *Activate Low Beam Headlights* and *Deactivate Low Beam Headlights* as well as *Control Cornering Light* is presented. The activation of the low beam headlights can be done under several conditions (see Section 3.2.2.1). When the low beam headlights are activated, they could either be deactivated (see Section 3.2.2.2) or the cornering light could be controlled (see Section 3.2.2.3). The several activation conditions are transmitted from the system function *Activate Low Beam Headlights* to the system function *Deactivate Low Beam Headlights*. Moreover, the system function *Control Cornering Light* needs to get informed about the activation status of the low beam headlights and can be prevented by the system function *Deactivate Low Beam Headlights* or enabled by the system function *Activate Low Beam Headlights*. Again, a more detailed description of the interactions with the context functions is given in the following on a lower level of abstraction.

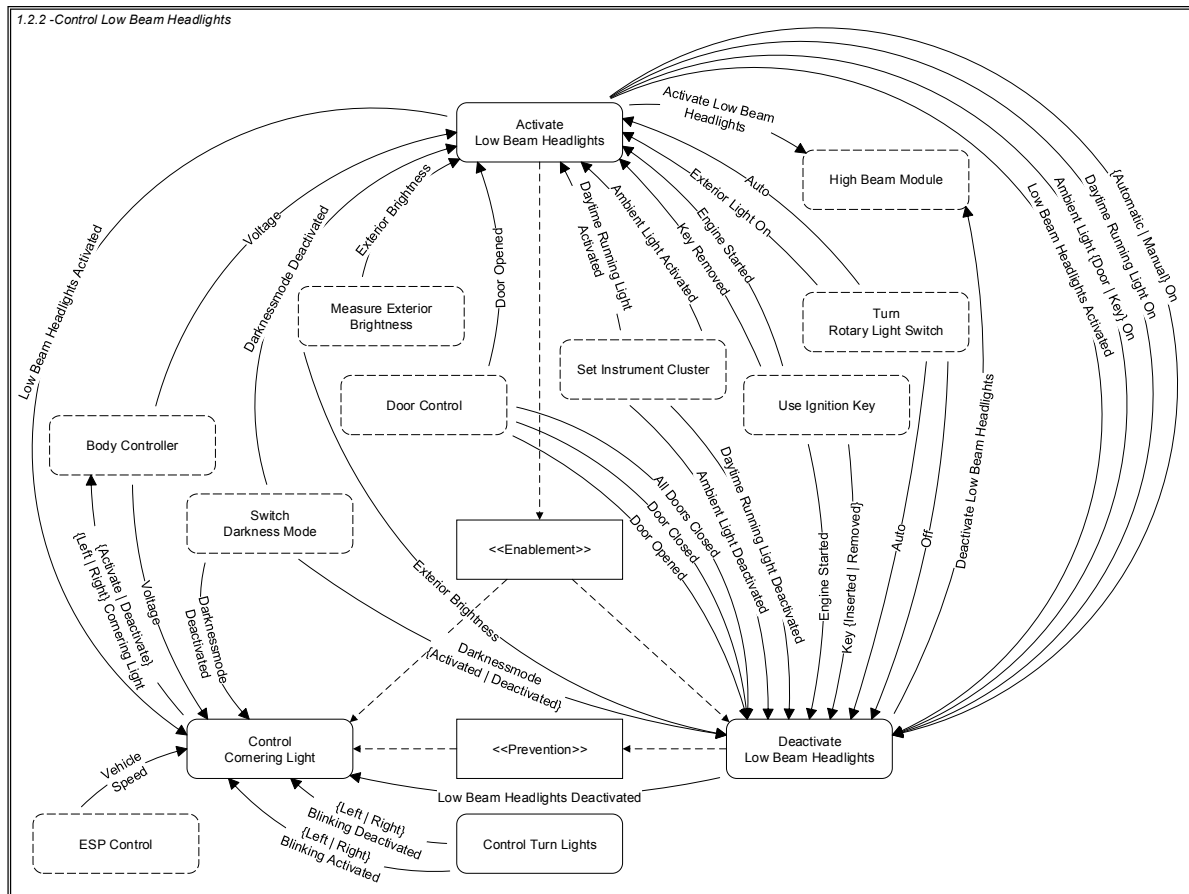

Figure 62: Function Network Diagram - Control Low Beam Headlights

### 3.2.2.1 Activate Low Beam Headlights

The activation of the low beam headlights can be done by the ambient light, the daytime running light, manually, or automatically (see Figure 63). Each activation ensures conditions without interdependencies to keep the low beam headlights active and needs to inform the system functions *Control Cornering Light* (cf. Section 3.2.2.3) and *Deactivate Low Beam Headlights* (cf. Section 3.2.2.2) about its status. In the following, the internal behavior of all possible activation functions and their interactions are described in detail.

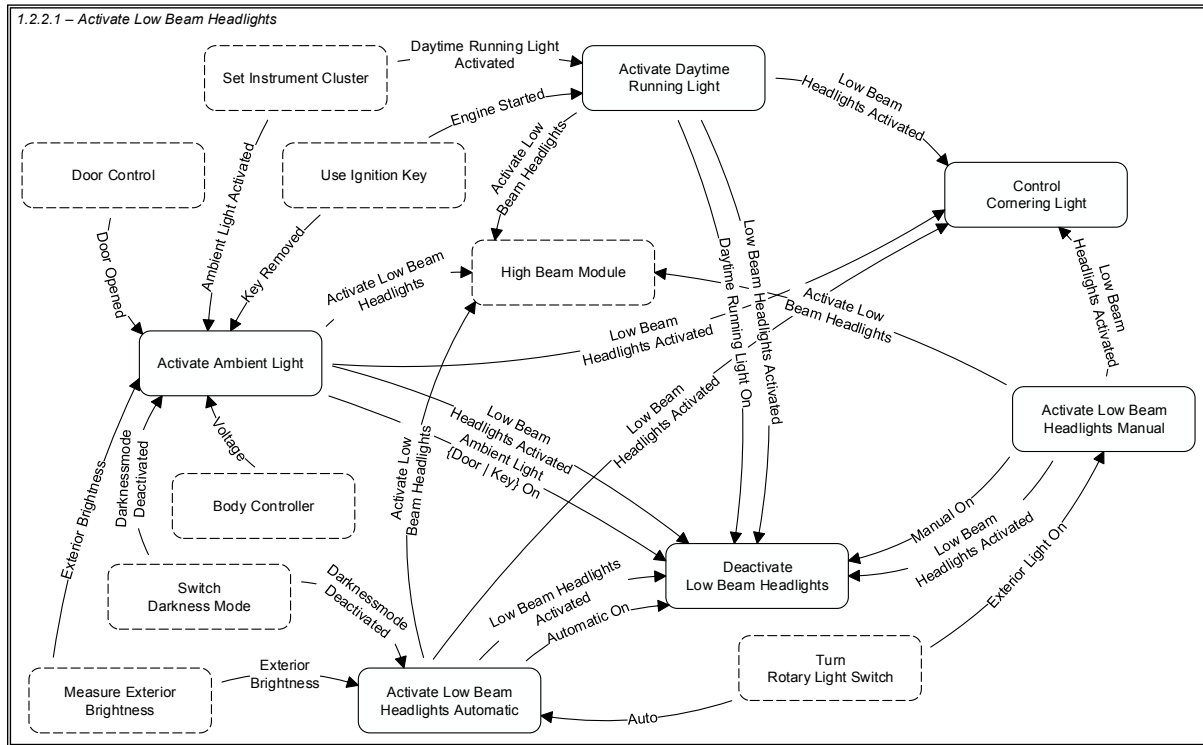
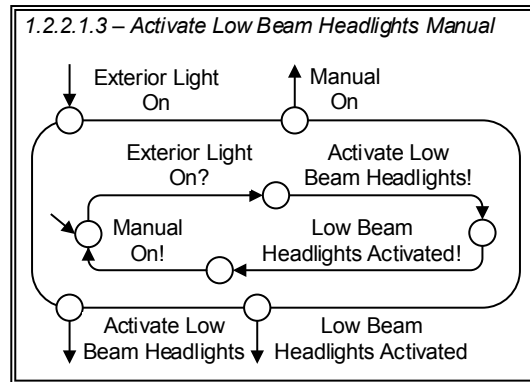

Figure 63: Function Network Diagram - Activate Low Beam Headlights

## Specification of the Functional Design

The manual activation of the low beam headlights is triggered when the exterior light is switched on (see Figure 64). This leads to the transmission of the messages *Activate Low Beam Headlights* to the context function *High Beam Module* and *Low Beam Headlights Activated* to the system function *Control Cornering Light*. Moreover, the system function *Deactivate Low Beam Headlight* gets informed about the manual activation.



**Figure 64: Interface Automaton - Activate Low Beam Headlights Manual**

When the rotary light switch is in auto mode and the darkness mode is deactivated (in armored vehicles), the exterior brightness from the context function *Measure Exterior Brightness* is checked (see Figure 65). If the exterior brightness is lower than a threshold  $S1$ , the low beam headlights are activated and automatic is set to on.

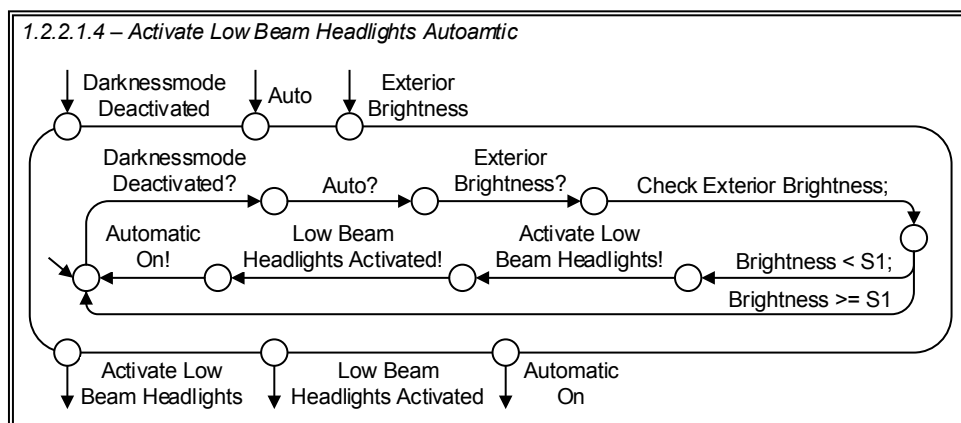

**Figure 65: Interface Automaton - Activate Low Beam Headlights Automatic**

When the daytime running light is activated by the context function *Set Instrument Cluster* and the engine gets started, the low beam headlights are activated and daytime running light is on (see Figure 66).

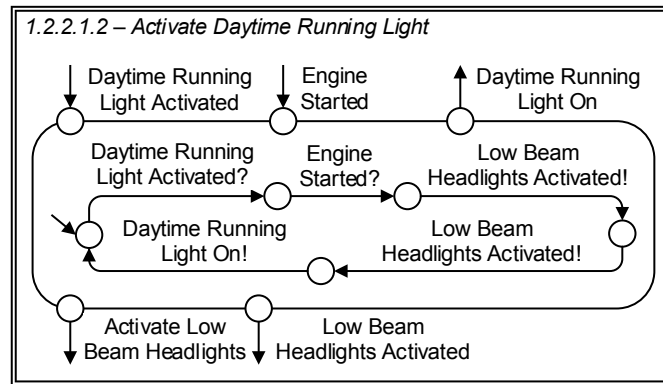

Figure 66: Interface Automaton - Activate Daytime Running Light

The system function *Activate Ambient Light* is divided into three system functions again (see Figure 67). First, the conditions for an activation need to be checked, and afterwards the ambient light could either be activated by door or by key.

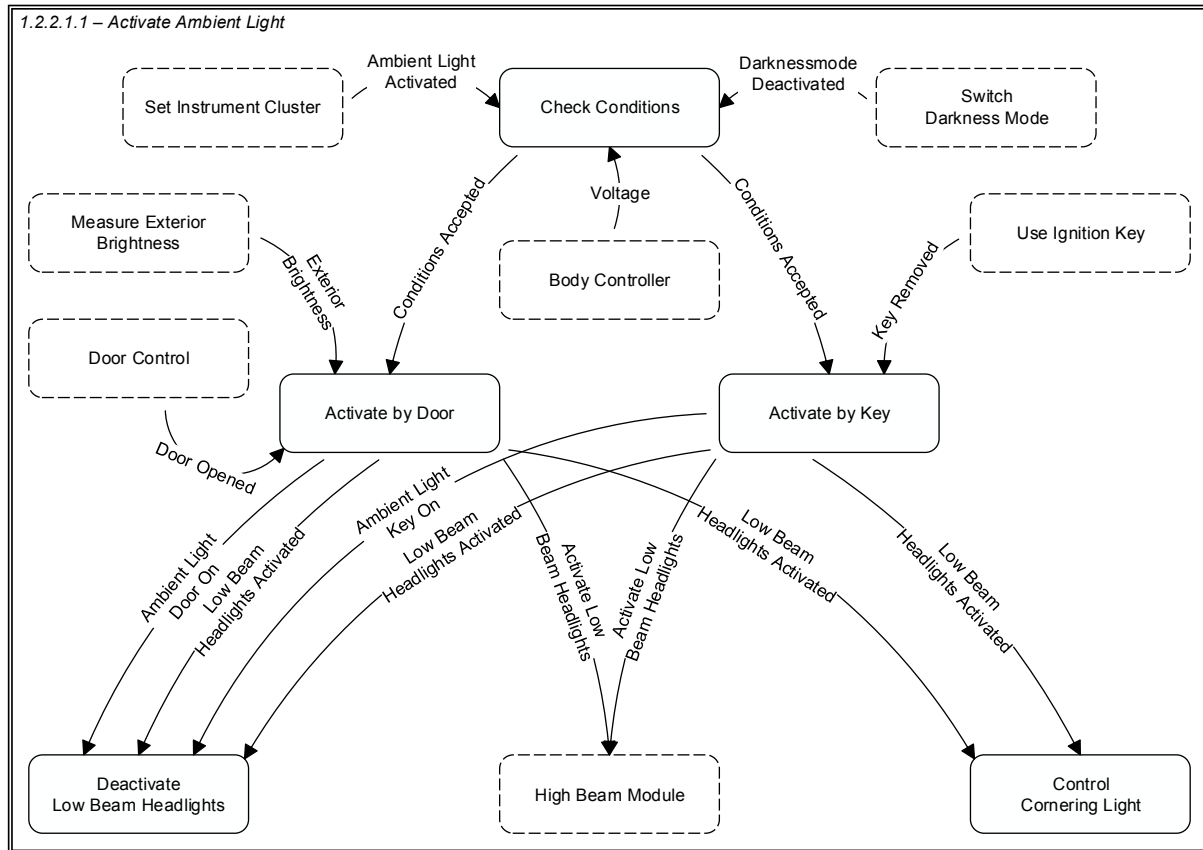

Figure 67: Function Network Diagram - Activate Ambient Light

The activation of the ambient light needs the activation in the instrument cluster and the deactivation of the darkness mode in armored vehicles (see Figure 68). In addition, the ambient light is not available with subvoltage, therefore the voltage gets checked.

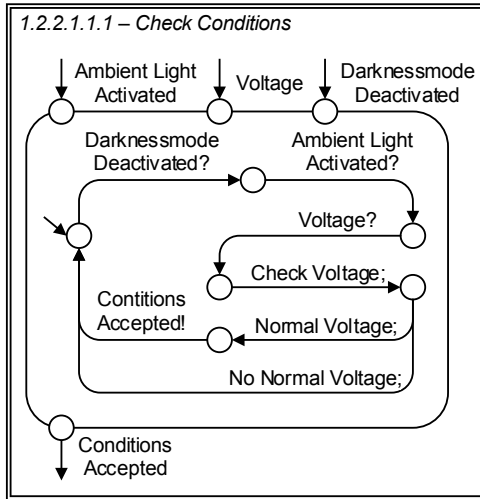

Figure 68: Interface Automaton - Check Conditions

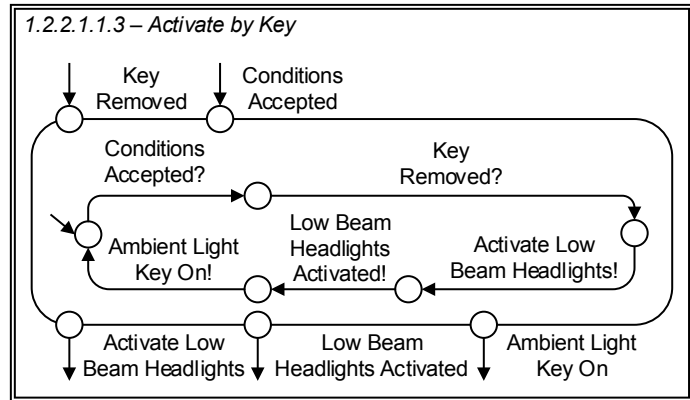

Figure 69: Interface Automaton - Activate by Key

If the preconditions are given, there are two alternatives to activate the ambient light. As soon as at least one door of the vehicle is opened and the exterior brightness is lower than the threshold  $S_1$ , the low beam headlights are activated and the ambient light is on via door (see Figure 70). Otherwise, the ambient light gets activated as soon as the engine is switched off and the ignition key is removed. In this case, the low beam headlights are activated and the ambient light is on via Key (see Figure 69).

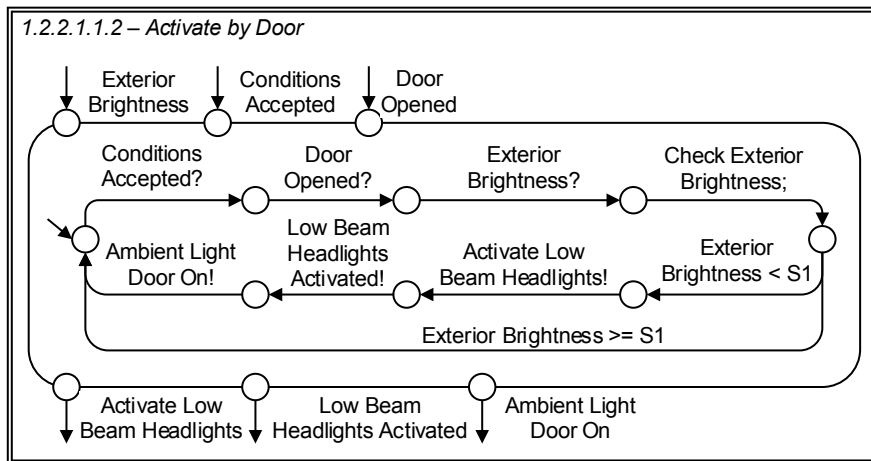

Figure 70: Interface Automaton - Activate by Door

### 3.2.2.2 Deactivate Low Beam Headlights

For the deactivation of the low beam headlights, none of the possible activation conditions must be enabled. Therefore, the four activation functions (cf. Section 3.2.2.1) need a deactivation function (see Figure 71). Every time a deactivation function is completed, the

## Specification of the Functional Design

conditions are checked and the low beam headlights either remain activated or become deactivated by the system function *Check Conditions and Switch Off*.

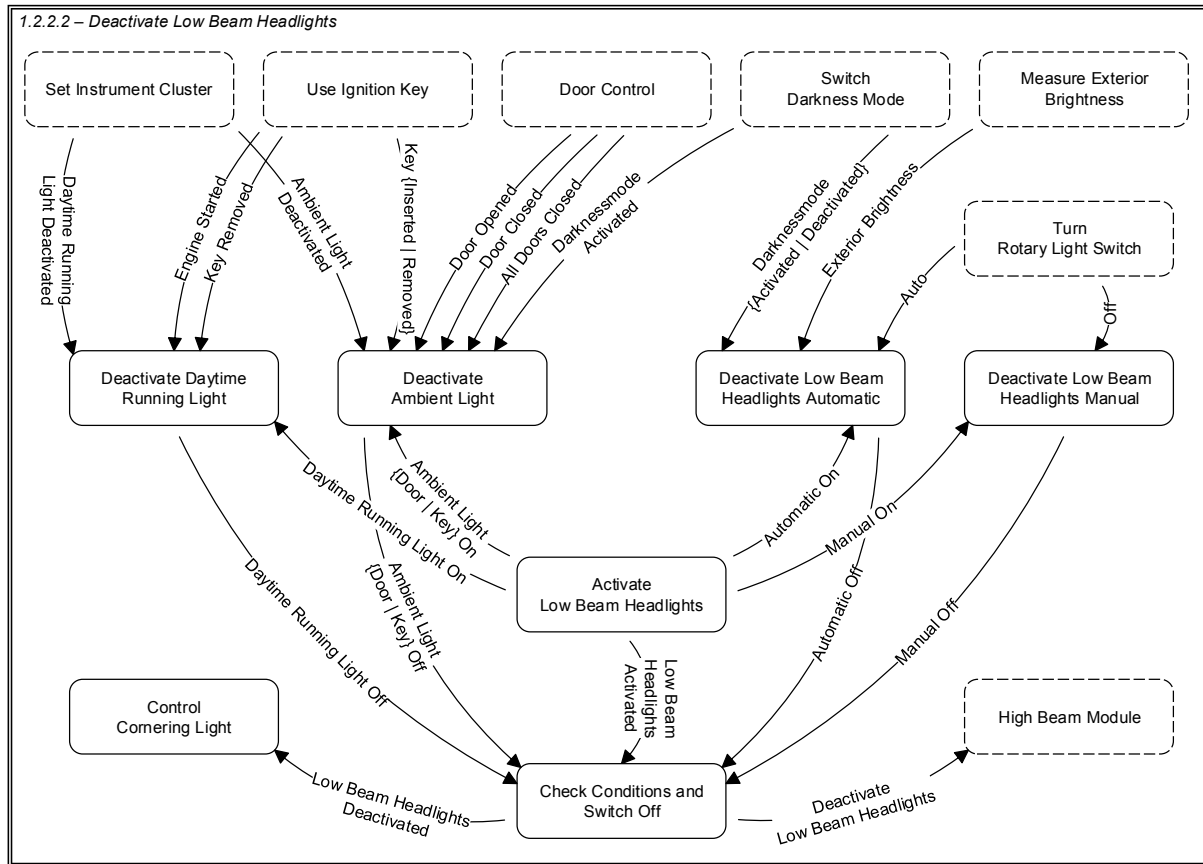

**Figure 71: Function Network Diagram - Deactivate Low Beam Headlights**

To deactivate the low beam headlights manually, the driver needs to switch the *rotary light switch* to off and the low beam headlights are *Manual Off* (see Figure 72).

When the darkness mode gets activated in armored vehicles, the automatic condition is set to off (see Figure 73). Otherwise, the exterior brightness gets checked and the low beam headlights are deactivated after exceeding a threshold S2.

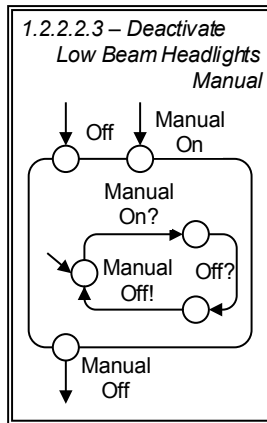

Figure 72: Interface Automaton - Deactivate Low Beam Headlights Manual

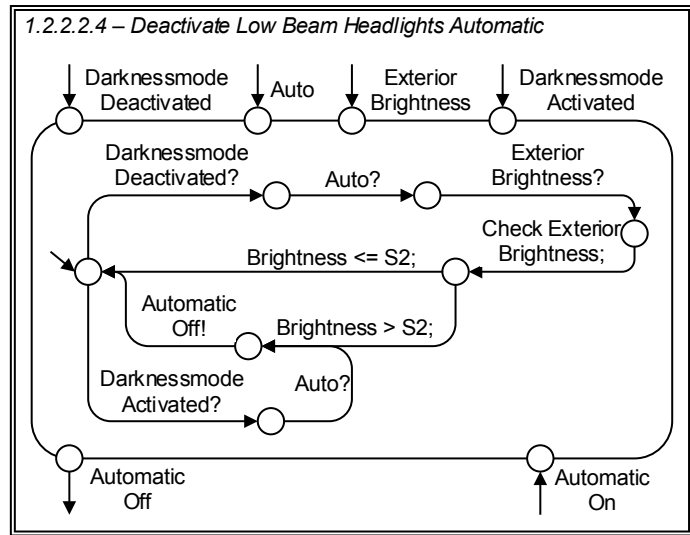

Figure 73: Interface Automaton - Deactivate Low Beam Headlights Automatic

The daytime running light gets deactivated either by deactivating the function in the *instrument cluster* or by removing the *ignition Key* (see Figure 74).

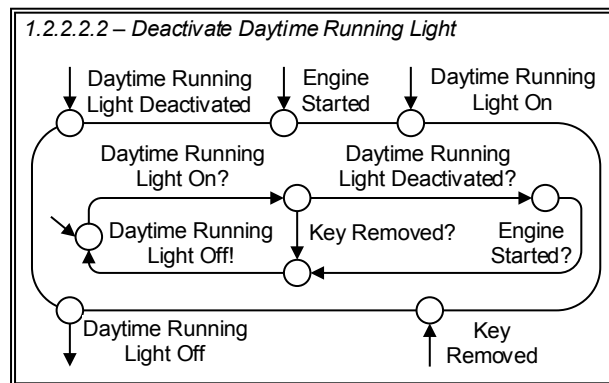

Figure 74: Interface Automaton - Deactivate Daytime Running Light

Figure 75 describes the four alternatives to deactivate the ambient light. In armored vehicles, the ambient light gets deactivated when the darkness mode is activated. When the ambient light is deactivated by the context function *Set Instrument Cluster*, the *Low Beam Headlight* immediately deactivated both activation conditions (door and key). The third alternative only concerns the activation via door and is triggered by the context function *Door Control* when all doors are closed. As long as the ambient light was activated by a key removal, the ambient light gets deactivated as soon as none of the actions open door, close door, insert or remove key occur within the next 30 seconds.



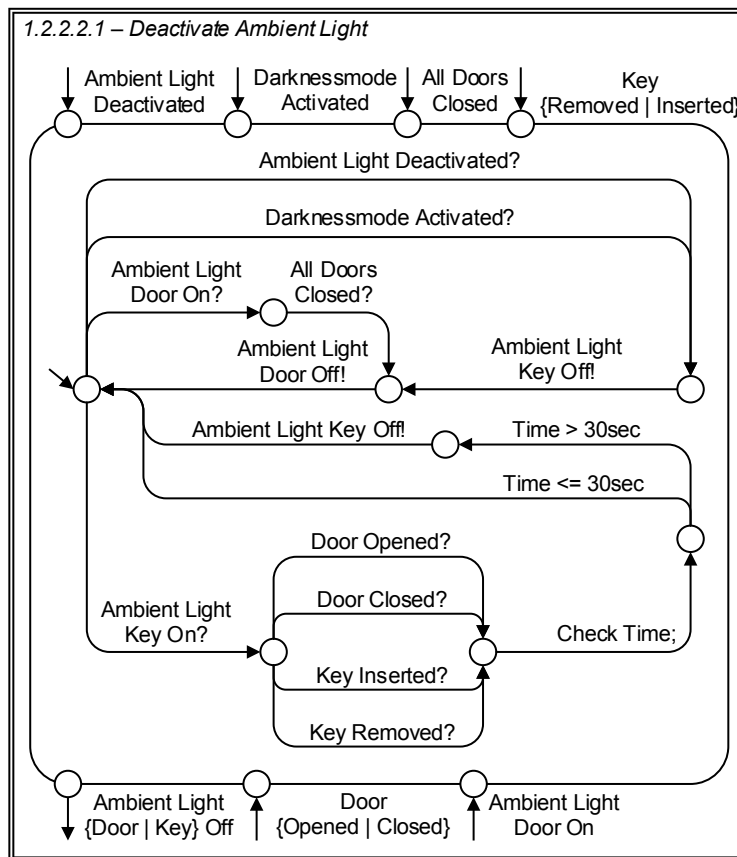

Figure 75: Interface Automaton - Deactivate Ambient Light

If one of the activation conditions of the low beam headlight was deactivated the conditions are checked, and only if all conditions are set to off, the low beam headlights get deactivated (see Figure 76). For reasons of clarity and comprehensibility the messages *Ambient Light Door Off*, *Ambient Light Key Off*, *Daytime Running Light Off*, *Automatic Off*, and *Manual Off* are modeled as a sequence, but the order is interchangeable.

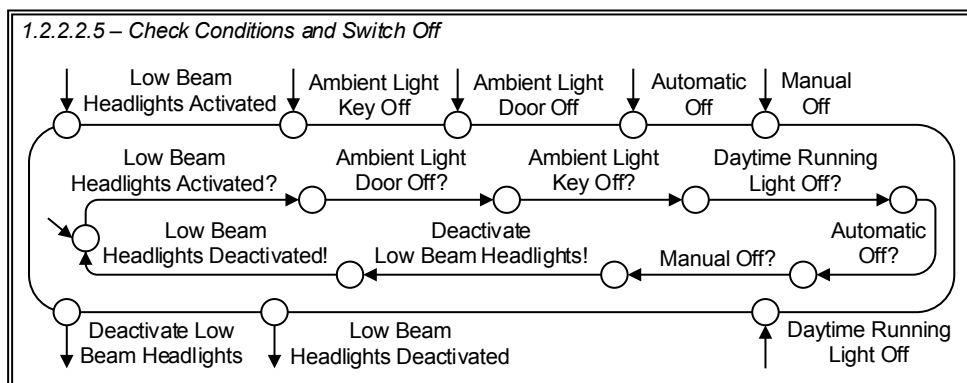

Figure 76: Interface Automaton - Check Conditions and Switch Off

### 3.2.2.3 Control Cornering Light

The system function *Control Cornering Light* is divided into the five system functions *Check Conditions*, *Activate Left Cornering Light*, *Activate Right Cornering Light*, *Deactivate Left Cornering Light*, and *Deactivate Right Cornering Light* (see Figure 77). The activation and deactivation is triggered by the system function *Control Turn Lights* (cf. Section 3.3) and for the activation it needs to receive the message *Conditions Accepted* by the system function *Check Conditions*.

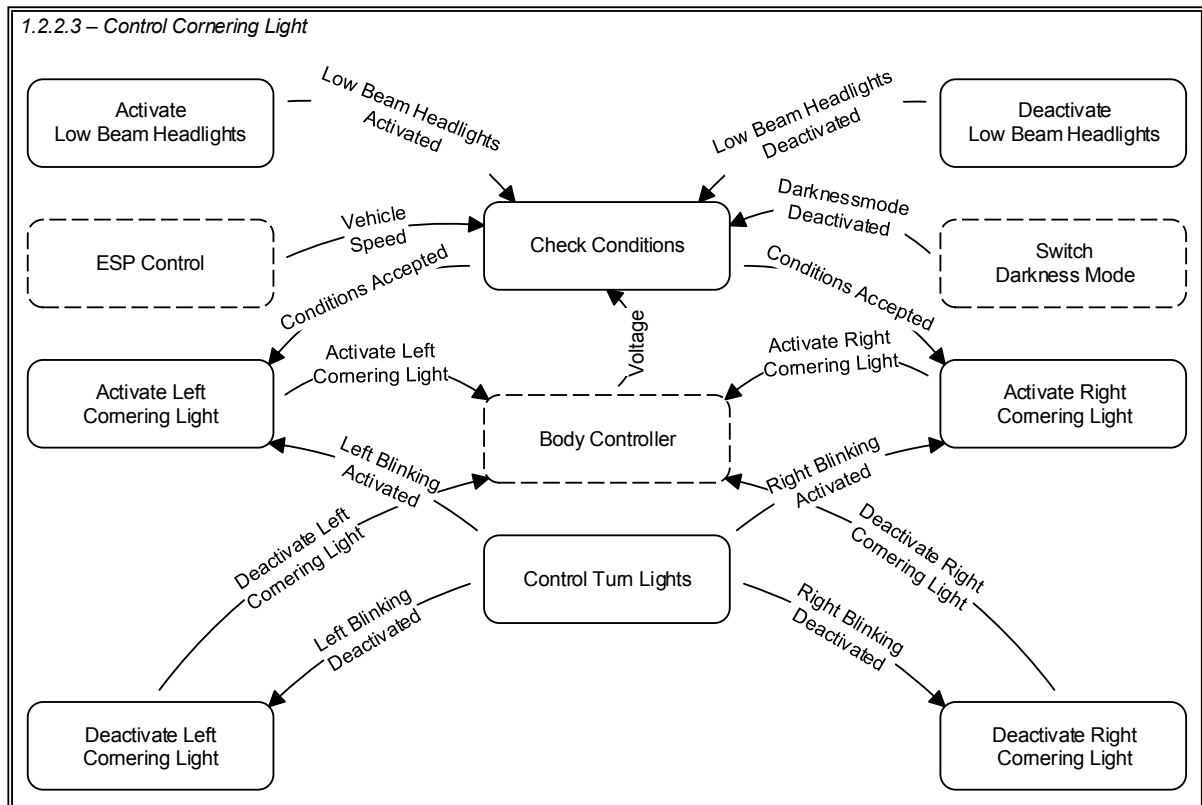

Figure 77: Function Network Diagram - Control Cornering Light

When the low beam headlights are activated, the darkness mode is deactivated. The conditions for an activation are met if the vehicle drives slower than 10 km/h and there is no subvoltage (see Figure 78).

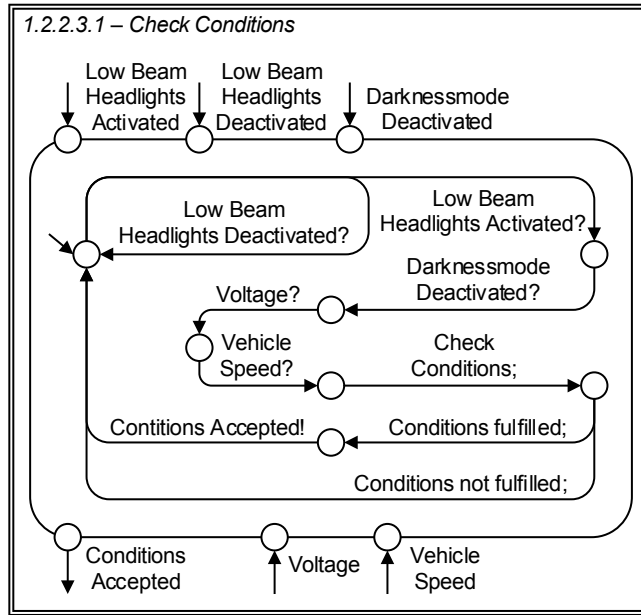

Figure 78: Interface Automaton - Check Conditions

To activate the left cornering light, the left blinking must be activated and the conditions must be met (see Figure 79), and to deactivate the left cornering light, the left blinking must be deactivated by the system function *Control Turn Lights* (see Figure 80).

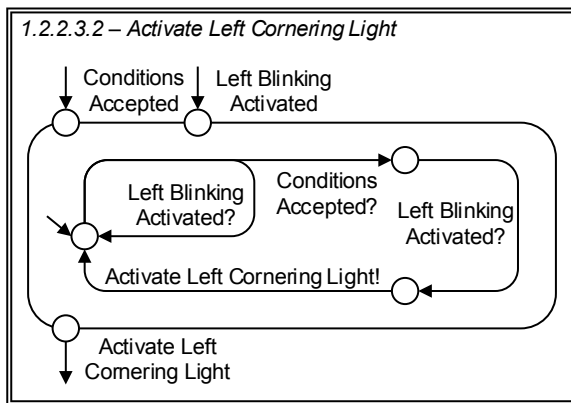

Figure 79: Interface Automaton - Activate Left Cornering Light

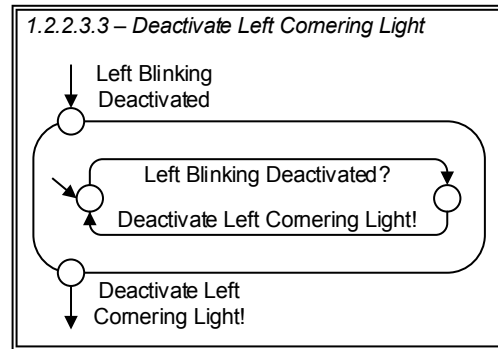

Figure 80: Interface Automaton - Deactivate Left Cornering Light

To activate the left cornering light, the left blinking must be activated and the conditions must be met (see Figure 81), and to deactivate the right cornering light, the left blinking must be deactivated by the system function *Control Turn Lights* (see Figure 80).

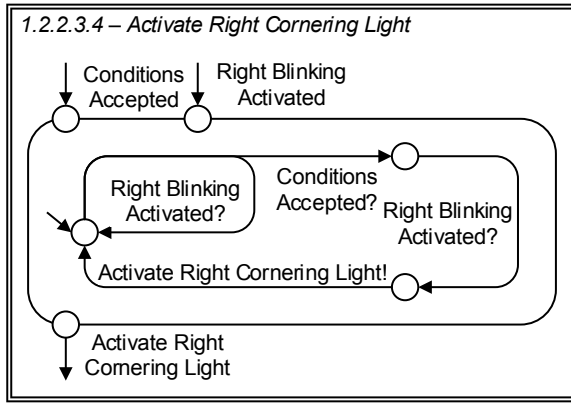

Figure 81: Interface Automaton - *Activate Right Cornering Light*

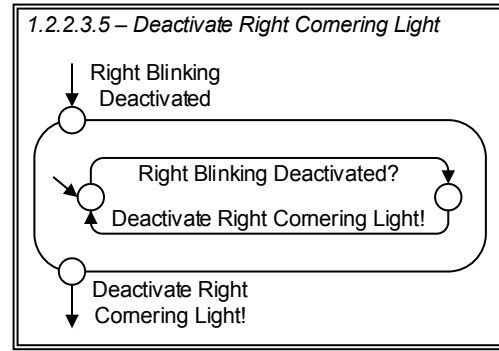

Figure 82: Interface Automaton - *Deactivate Right Cornering Light*

### 3.2.3 Handle Overvoltage

To protect the illuminants from burning out in case of an occurring overvoltage, the pulse width gets adapted via the *High Beam Module* and the *Body Controller* (see Figure 83).

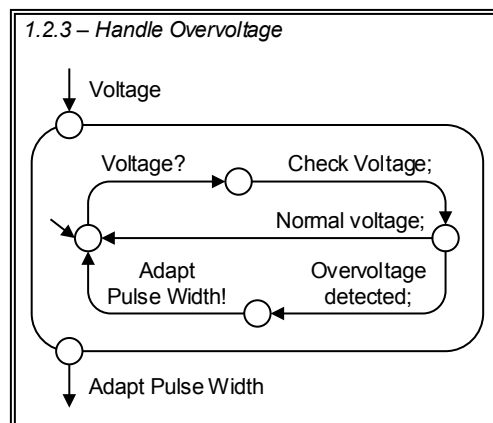

Figure 83: Interface Automaton - *Handle Overvoltage*

## 3.3 Control Turn Signal

The system function *Control Turn Lights* is subdivided into the eight system functions *Activate Hazard Warning Light*, *Deactivate Hazard Warning Light*, *Activate Tip Blinking Right*, *Activate Direction Blinking Right*, *Deactivate Direction Blinking Right*, *Activate Tip Blinking Left*, *Activate Direction Blinking Left*, and *Deactivate Direction Blinking Left* (cf. Figure 84 and Figure 85). Compared to Figure 54 in Section 3.1, the interactions with the context functions are distributed and the system function *Control Headlights* receives the status of direction blinking from several system functions (cf. Figure 84). For reasons of clarity and comprehensibility, there are two overviews of the system function *Control Turn Lights*. In

## Specification of the Functional Design

Figure 84, only the interactions and messages between system and context functions are presented, and in Figure 85 an overview of the dependencies of the system functions is given.

Basically, the messages for activation and deactivation of a direction indicator are transmitted to the context functions *Door Control* and *Body Controller*, which are responsible for the physical control of all direction indicators. The message *Pulse Ratio* is used to adjust the bright to dark ratio of each direction indicator.

To control the hazard warning light, the system functions *Activate Hazard Warning Light* and *Deactivate Hazard Warning Light* receive the messages containing the current settings of the hazard warning light switch and the status of the ignition key. As an output the Left and Right Blinking is either activated or deactivated. The internal behavior of these two system functions is presented in Section 3.3.3. The other six system functions on this level of abstraction control the left (cf. Section 3.3.1) and right (cf. Section 3.3.2) turn signals.

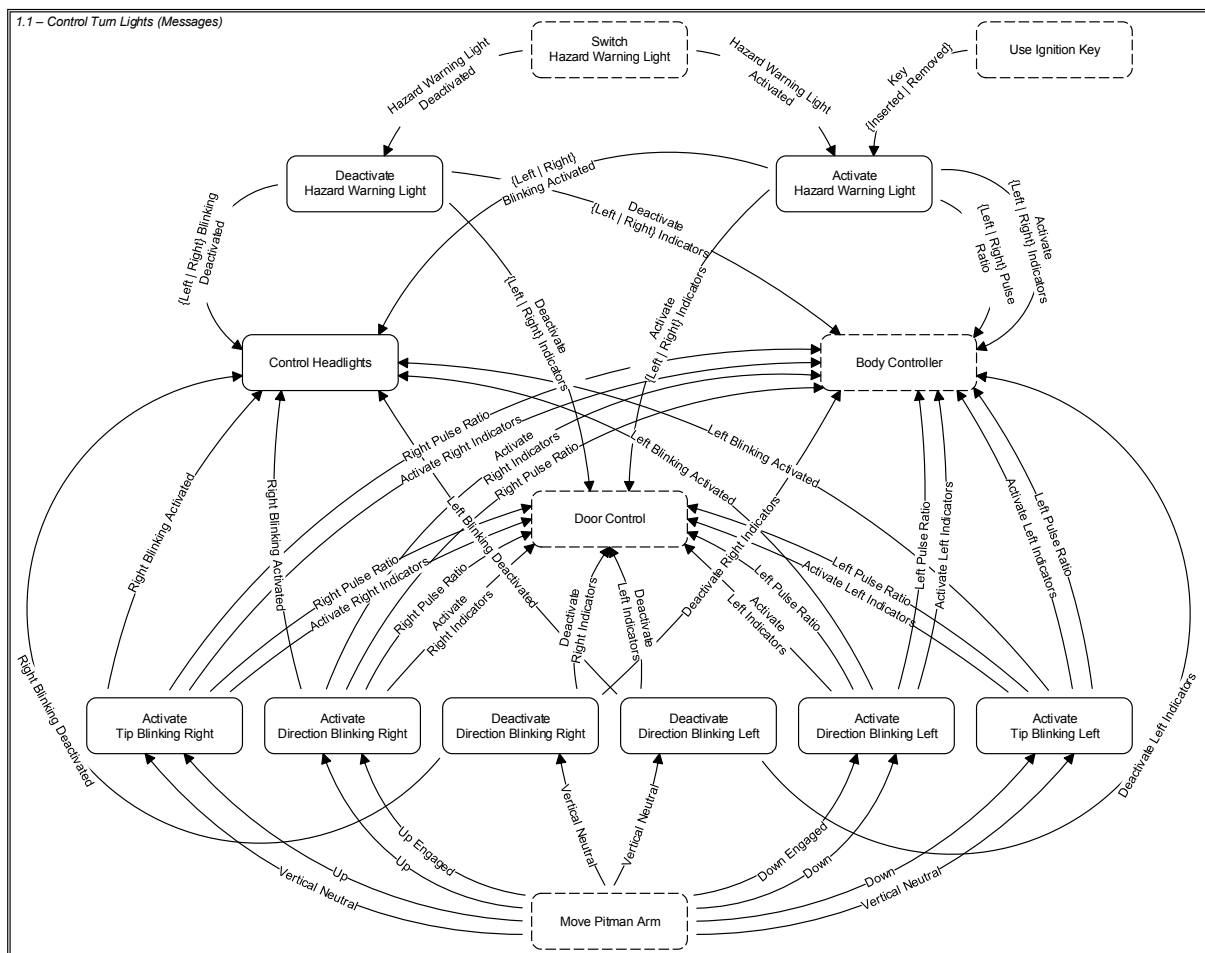

Figure 84: Function Network Diagram - Control Turn Lights (Messages)

In Figure 85, all dependencies between the system functions are modeled explicitly. For example, it is only possible to control the blinking functionalities when the hazard warning light is deactivated. Moreover, the left and right blinking functionalities prevent each other, as it is only possible to blink for one direction.

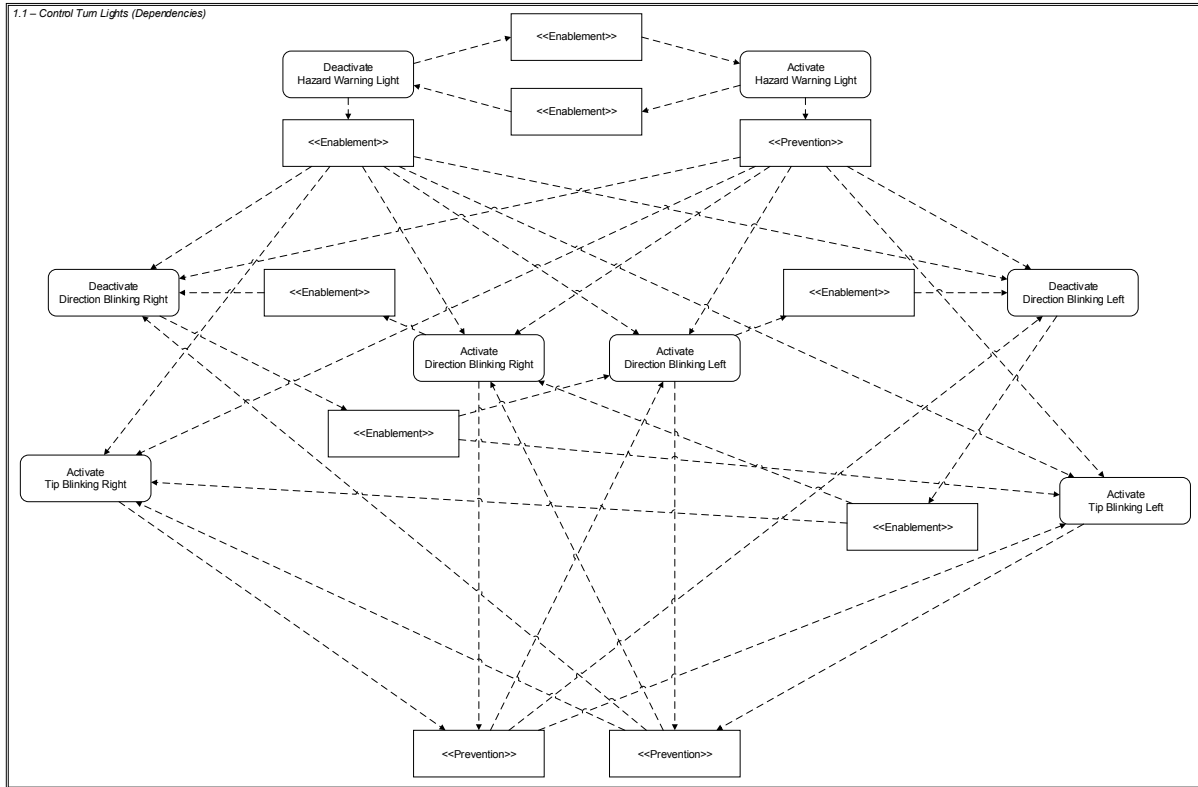

Figure 85: Function Network Diagram - Control Turn Lights (Dependencies)

### 3.3.1 Direction Blinking Left

The activation of the left direction blinking is triggered by the context function *Move Pitman Arm* and its position *Down* or *Down Engaged* (see Figure 86). This leads to the activation of the left direction indicators with a pulse ratio bright to dark 1:1 by transmitting the messages *Activate Left Indicators* and *Left Pulse Ratio* to the context functions *Body Controller* and *Door Control*. Moreover, the system function *Control Headlights* gets informed by the message *Left Blinking Activated* (cf. Figure 84). For reasons of clarity and comprehensibility, the messages *Activate Left Indicators*, *Left Blinking Activated*, and *Left Pulse Ratio* are modeled as a sequence, but the order of *Activate Left Indicators* and *Left Pulse Ratio* is interchangeable.

To deactivate the left direction blinking, the pitman arm needs to be moved to the vertical neutral position (see Figure 87). In this case, the direction blinking left gets deactivated via the context functions *Body Controller* and the *Door Control* and the system function *Control Headlights* gets informed.

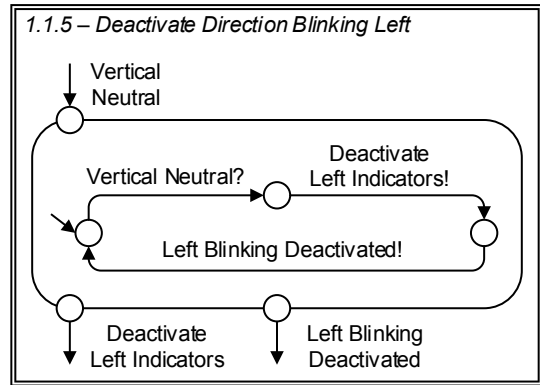
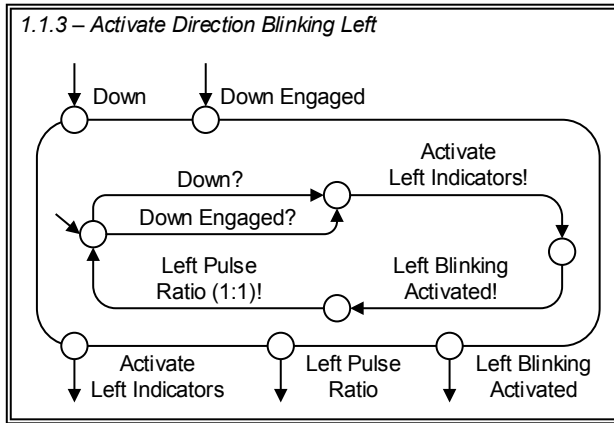

Figure 86: Interface Automaton - Activate Direction Blinking Left

Figure 87: Interface Automaton - Deactivate Direction Blinking Left

When the pitman arm position is moved to down for less than 0.5 seconds, the left tip blinking is activated (see Figure 88). The activation of tip blinking leads to an activation of the left direction indicators for three flashing cycles. Just as in Figure 86, the messages *Activate Left Indicators*, *Left Blinking Activated*, and *Left Pulse Ratio* are modeled as a sequence for reasons of clarity and comprehensibility, but the order of *Activate Left Indicators* and *Left Pulse Ratio* is interchangeable.

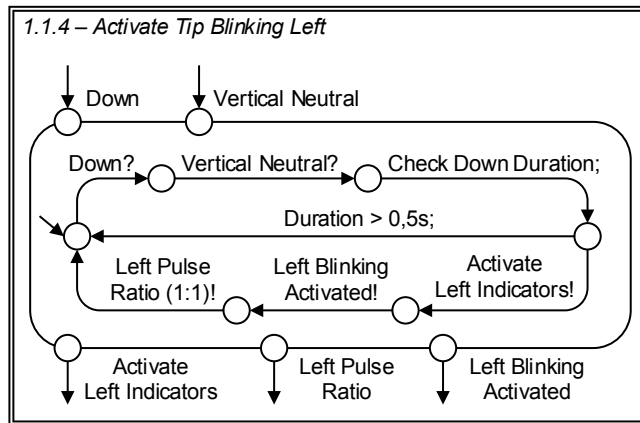

Figure 88: Interface Automaton - Activate Tip Blinking Left

### 3.3.2 Direction Blinking Right

The right direction and tip blinking is analogous to the left side (compare Figure 89 with Figure 86, Figure 90 with Figure 88, and Figure 87 with Figure 91).

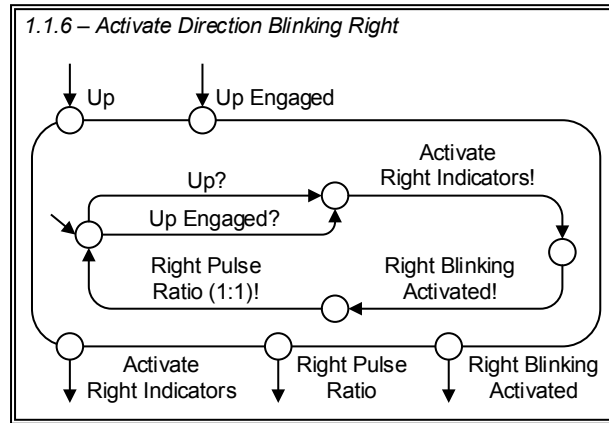

Figure 89: Interface Automaton - Activate Direction Blinking Right

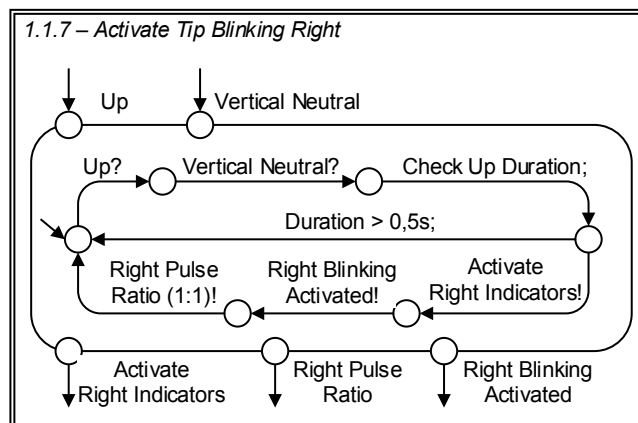

Figure 90: Interface Automaton - Activate Tip Blinking Right

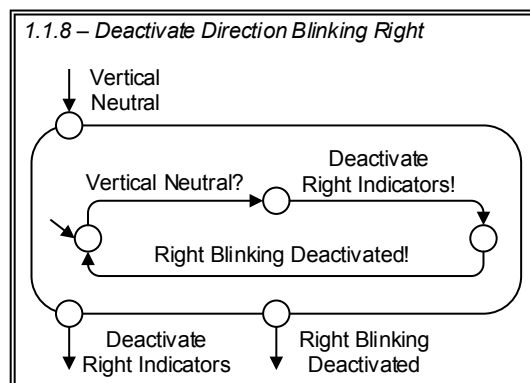

Figure 91: Interface Automaton - Deactivate Direction Blinking Right



### 3.3.3 Hazard Warning Light

When the hazard warning light gets activated via the context function *Switch Hazard Warning Light* (cf. Figure 84), the left and right direction indicators get activated via the context functions *Body Controller* and *Door Control* (see Figure 92). Again, the system function *Control Headlight* is informed by the messages *Left Blinking Activated* and *Right Blinking Activated*. In Figure 92, the interchangeability of messages concerning the left and right indicators is modeled explicitly. For energy saving reasons, the pulse ratio is reduced (bright to dark 1:2) when the ignition key is removed.

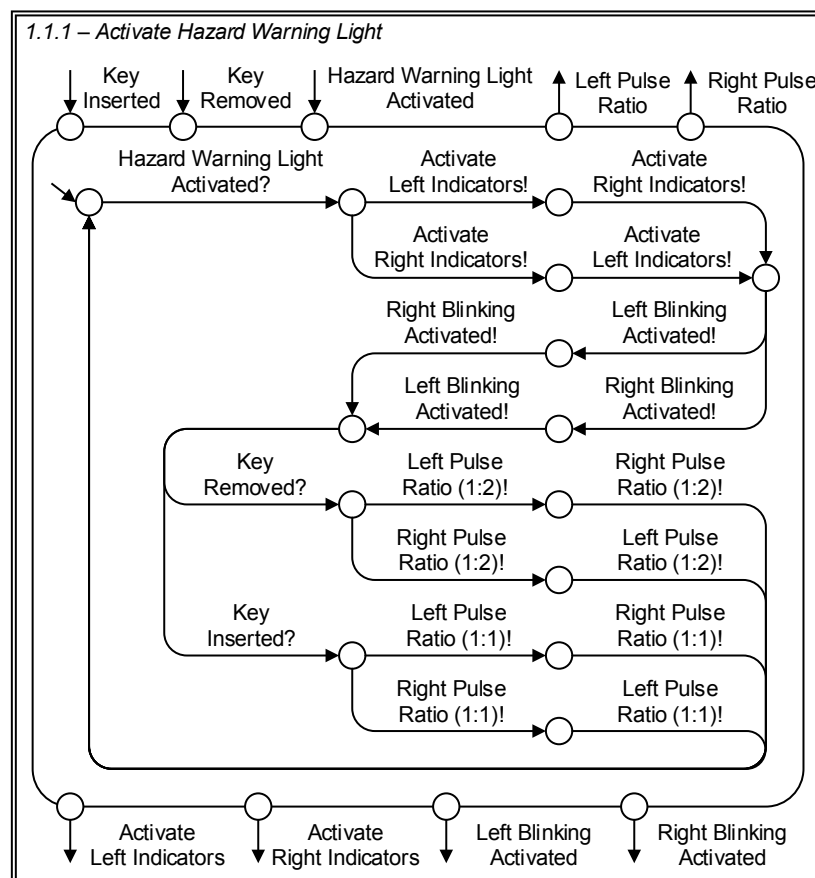

Figure 92: Interface Automaton - Activate Hazard Warning Light

The deactivation is also triggered by the context function *Switch Hazard Warning Light* (cf. Figure 84), and the left and right direction indicators get deactivated via the context functions *Body Controller* and *Door Control* (see Figure 93). Again, the system function *Control Headlight* is informed by the messages *Left Blinking Deactivated* and *Right Blinking Deactivated*.

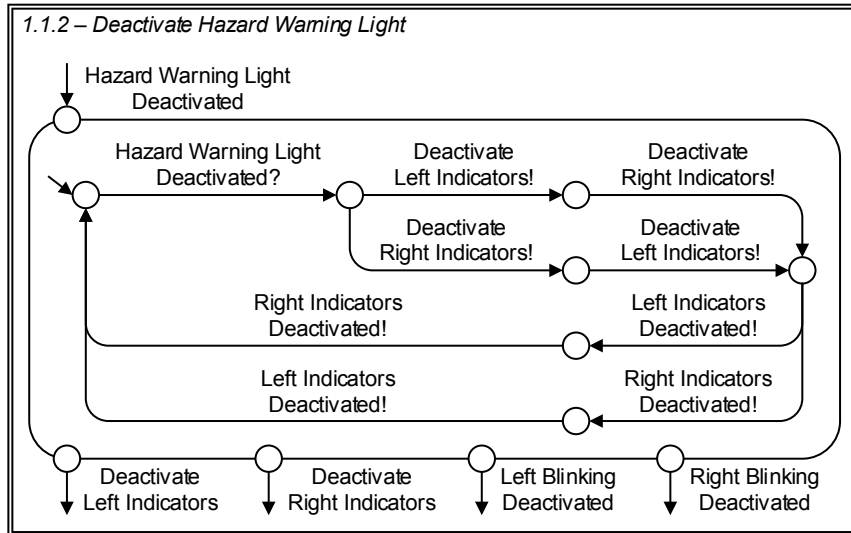

Figure 93: Interface Automaton - *Deactivate Hazard Warning Light*

### 3.4 Defect Faults

The system function *Detect Faults* uses the message *Illuminant Status* from the context functions *Body Controller* and *High Beam Module* to check these statuses and to identify defective illuminants. The information about defective illuminants is then transmitted to the context function *Set Instrument Cluster* (cf. Figure 54 in Section 3.1). This behavior is presented in Figure 94.

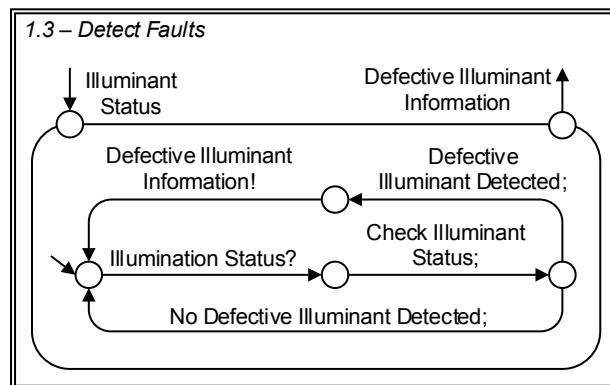

Figure 94: Interface Automaton - *Detect Faults*

## 4 References

- Beetz K, Böhm DW (2012) Challenges in Engineering for Software-Intensive Embedded Systems. In: Pohl K, Hönniger H, Achatz R, Broy M (eds) Model-Based Engineering of Embedded Systems. Springer Berlin Heidelberg, pp 3–14
- Brinkkemper S, Pachidi S (2010) Functional Architecture Modeling for the Software Product Industry. In: Babar MA, Gorton I (eds) Software Architecture. Springer Berlin Heidelberg, pp 198–213
- Daun M, Tenbergen B, Weyer DT (2012) Requirements Viewpoint. In: Pohl K, Hönniger H, Achatz R, Broy M (eds) Model-Based Engineering of Embedded Systems. Springer Berlin Heidelberg, pp 51–68
- Daun M, Weyer T, Pohl K (2014) Validating the Functional Design of Embedded Systems against Stakeholder Intentions: Proceedings of the 2nd International Conference on Model-Driven Engineering and Software Development 2014. SCITEPRESS - Science and and Technology Publications, pp 333–339
- De Alfaro L, Henzinger TA (2001) Interface Automata. Proceedings of the 8th European Software Engineering Conference Held Jointly with 9th ACM SIGSOFT International Symposium on Foundations of Software Engineering. ACM, New York, NY, USA, pp 109–120
- Houdek F (2013) System Requirements Specification Automotive System Cluster (ELC and ACC). Technical University of Munich
- ITU (2011) Recommendation ITU-T Z.120: Message Sequence Chart (MSC). International Telecommunication Union
- Jantsch A, Sander I (2000) On the roles of functions and objects in system specification. Proceedings of the Eighth International Workshop on Hardware/Software Codesign, 2000. CODES 2000. pp 8–12
- Pretschner A, Broy M, Kruger IH, Stauner T (2007) Software Engineering for Automotive Systems: A Roadmap. 2007 Future of Software Engineering. IEEE Computer Society, Washington, DC, USA, pp 55–71
- Sikora E, Tenbergen B, Pohl K (2012) Industry needs and research directions in requirements engineering for embedded systems. Requirements Eng 17:57–78. doi: 10.1007/s00766-011-0144-x
- Weber M, Weisbrod J (2002) Requirements engineering in automotive development-experiences and challenges. IEEE Joint International Conference on Requirements Engineering, 2002. Proceedings. pp 331–340



## Previously published ICB - Research Reports

### 2015

No 63 (January)

*Schauer, Carola; Schauer, Hanno: „IT an allgemeinbildenden Schulen: Bildungsgegenstand und -infrastruktur – Auswertung internationaler empirischer Studien und Literaturanalyse“*

### 2014

No 62 (October)

*Köninger, Stephan; Heß, Michael: „Konzeption und Implementierung eines Software-Werkzeuges zur multiperspektivischen Bewertung innovativer Produkte, Projekte und Dienstleistungen im Projekt Hospital Engineering“*

No 61 (May)

*Schauer, Carola; Frank, Ulrich: „Wirtschaftsinformatik an Schulen. Status und Desiderata mit Fokus auf Nordrhein-Westfalen“*

No 60 (May)

*Heß, Michael: „Multiperspektivische Dokumentation und Informationsbedarfsanalyse kardiologischer Prozesse sowie Konzeptualisierung ausgewählter medizinischer Ressourcentypen im Projekt Hospital Engineering“*

No 59 (May)

*Goedicke, Michael; Kurt-Karaoglu, Filiz; Schwinning, Nils; Schypula, Melanie; Striewe, Michael: „Zweiter Jahresbericht zum Projekt „Bildungsgerechtigkeit im Fokus“ (Teilprojekt 1.2 - „Blended Learning“) an der Fakultät für Wirtschaftswissenschaften“*

No 58 (March)

*Breitschwerdt, Rüdiger; Heß, Michael: „Konzeption eines Bezugsrahmens zur Analyse und Entwicklung von Geschäftsmodellen mobiler Gesundheitsdienstleistungen – Langfassung“*

No 57 (March)

*Heß, Michael; Schlieter, Hannes (Hrsg.): „Modellierung im Gesundheitswesen – Tagungsband des Workshops im Rahmen der »Modellierung 2014«“*

### 2013

No 56 (July)

*Svensson, Richard Berntsson; Berry, Daniel M.; Daneva, Maya; Doerr, Joerg; Espana, Sergio; Herrmann, Andrea; Herzwurm, Georg; Hoffmann, Anne; Pena, Raul Mazo; Opdahl, Andreas L.; Pastor, Oscar; Pietsch, Wolfram; Salinesi, Camille; Schneider, Kurt; Seyff, Norbert; van de Weerd, Inge; Wieringa, Roel; Wnuk, Krzysztof (Eds.): „19th International Working Conference on Requirements Engineering: Foundation for Software Quality (REFSQ 2013). Proceedings of the REFSQ 2013 Workshops CreaRE, IWSPM, and RePriCo, the REFSQ 2013 Empirical Track (Empirical Live Experiment and Empirical Research Fair), the REFSQ 2013 Doctoral Symposium, and the REFSQ 2013 Poster Session“*

No 55 (May)

*Daun, Marian; Focke, Markus; Holtmann, Jörg; Tenbergen, Bastian: "Goal-Scenario- Oriented Requirements Engineering for Functional Decomposition with Bidirectional Transformation to Controlled Natural Language. Case Study »Body Control Module«"*

No 54 (March)

*Fischotter, Melanie; Goedicke, Michael; Kurz-Karaoglu, Filiz; Schwinning, Nils; Striewe, Michael: "Erster Jahresbericht zum Projekt „Bildungsgerechtigkeit im Fokus“ (Teilprojekt 1.2 – „Blended Learning“) an der Fakultät für Wirtschaftswissenschaften“*

## 2012

No 53 (December)

*Frank, Ulrich: "Thoughts on Classification / Instantiation and Generalisation / Specialisation"*

No 52 (July)

*Berntsson-Svensson, Richard; Berry, Daniel; Daneva, Maya; Dörr, Jörg; Fricker, Samuel A.; Hermann, Andrea; Herzwurm, Georg; Kauppinen, Marjo; Madhayji, Nazim H.; Mahaux, Martin; Paech, Barbara; Penzenstadler, Birgit; Pietsch, Wolfram; Salinesi, Camille; Schneider, Kurt; Seyff, Norbert; van de Weerd, Inge: "18th International Working Conference on Requirements Engineering: Foundation for Software Quality. Proceedings of the Workshops RE4SuSy, REEW, CreaRE, RePriCo, IWSPM and the Conference Related Empirical Study, Empirical Fair and Doctoral Symposium"*

No 51 (May)

*Frank, Ulrich: "Specialisation in Business Process Modelling: Motivation, Approaches and Limitations"*

No 50 (March)

*Adelsberger, Heimo; Drechsler, Andreas; Herzig, Eric; Michaelis, Alexander; Schulz, Philip; Schütz, Stefan; Ulrich, Udo: "Qualitative und quantitative Analyse von SOA-Studien. Eine Metastudie zu serviceorientierten Architekturen"*

## 2011

No 49 (December)

*Frank, Ulrich: "MEMO Organisation Modelling Language (2): Focus on Business Processes"*

No 48 (December)

*Frank, Ulrich: "MEMO Organisation Modelling Language (1): Focus on Organisational Structure"*

No 47 (December)

*Frank, Ulrich: "MEMO Organisation Modelling Language: Requirements and Core Diagram Types"*

No 46 (December)

*Frank, Ulrich: "Multi-Perspective Enterprise Modelling: Background and Terminological Foundation"*

No 45 (November)

*Frank, Ulrich; Strecker, Stefan; Heise, David; Kattenstroth, Heiko; Schauer, Carola: "Leitfaden zur Erstellung wissenschaftlicher Arbeiten in der Wirtschaftsinformatik"*

No 44 (September)

*Berenbach, Brian; Daneva, Maya; Dörr, Jörg; Fricker, Samuel; Gervasi, Vincenzo; Glinz, Martin; Hermann, Andrea; Krams; Benedikt; Madhavji, Nazim H.; Paech, Barbara; Schockert, Sixten; Seyff, Norbert (Eds): "17th International Working Conference on Requirements Engineering: Foundation for Software Quality (REFSQ 2011). Proceedings of the REFSQ 2011 Workshops REEW, EPICAL and RePriCo, the REFSQ 2011 Empirical Track (Empirical Live Experiment and Empirical Research Fair), and the REFSQ 2011 Doctoral Symposium"*

No 43 (February)

*Frank, Ulrich: "The MEMO Meta Modelling Language (MML) and Language Architecture – 2nd Edition"*

## **2010**

No 42 (December)

*Frank, Ulrich: "Outline of a Method for Designing Domain-Specific Modelling Languages"*

No 41 (December)

*Adelsberger, Heimo; Drechsler, Andreas (Eds): "Ausgewählte Aspekte des Cloud-Computing aus einer IT-Management-Perspektive – Cloud Governance, Cloud Security und Einsatz von Cloud Computing in jungen Unternehmen"*

No 40 (October 2010)

*Bürsner, Simone; Dörr, Jörg; Gehlert, Andreas; Herrmann, Andrea; Herzwurm, Georg; Janzen, Dirk; Merten, Thorsten; Pietsch, Wolfram; Schmid, Klaus; Schneider, Kurt; Thurimella, Anil Kumar (Eds): "16th International Working Conference on Requirements Engineering: Foundation for Software Quality. Proceedings of the Workshops CreaRE, PLREQ, RePriCo and RESC"*

No 39 (May 2010)

*Strecker, Stefan; Heise, David; Frank, Ulrich: "Entwurf einer Mentoring-Konzeption für den Studiengang M.Sc. Wirtschaftsinformatik an der Fakultät für Wirtschaftswissenschaften der Universität Duisburg-Essen"*

No 38 (February 2010)

*Schauer, Carola: "Wie praxisorientiert ist die Wirtschaftsinformatik? Einschätzungen von CIOs und WI-Professoren"*

No 37 (January 2010)

*Benavides, David; Batory, Don; Grunbacher, Paul (Eds.): "Fourth International Workshop on Variability Modelling of Software-intensive Systems"*

## **2009**

No 36 (December 2009)

*Strecker, Stefan: "Ein Kommentar zur Diskussion um Begriff und Verständnis der IT-Governance - Anregungen zu einer kritischen Reflexion"*

No 35 (August 2009)

*Rüngeler, Irene; Tüxen, Michael; Rathgeb, Erwin P.: "Considerations on Handling Link Errors in STCP"*

No 34 (June 2009)

*Karastoyanova, Dimka; Kazhamiakan, Raman; Metzger, Andreas; Pistore, Marco (Eds.): "Workshop on Service Monitoring, Adaption and Beyond"*

No 33 (May 2009)

*Adelsberger, Heimo; Drechsler, Andreas; Bruckmann, Tobias; Kalvelage, Peter; Kinne, Sophia; Pellingner, Jan; Rosenberger, Marcel; Trepper, Tobias: „Einsatz von Social Software in Unternehmen – Studie über Umfang und Zweck der Nutzung“*

No 32 (April 2009)

*Barth, Manfred; Gadatsch, Andreas; Kütz, Martin; Rüdiger, Otto; Schauer, Hanno; Strecker, Stefan: „Leitbild IT-Controller/-in – Beitrag der Fachgruppe IT-Controlling der Gesellschaft für Informatik e. V.“*

No 31 (April 2009)

*Frank, Ulrich; Strecker, Stefan: "Beyond ERP Systems: An Outline of Self-Referential Enterprise Systems – Requirements, Conceptual Foundation and Design Options"*

No 30 (February 2009)

*Schauer, Hanno; Wolff, Frank: „Kriterien guter Wissensarbeit – Ein Vorschlag aus dem Blickwinkel der Wissenschaftstheorie (Langfassung)“*

No 29 (January 2009)

*Benavides, David; Metzger, Andreas; Eisenecker, Ulrich (Eds.): "Third International Workshop on Variability Modelling of Software-intensive Systems"*

## **2008**

No 28 (December 2008)

*Goedicke, Michael; Striewe, Michael; Balz, Moritz: „Computer Aided Assessments and Programming Exercises with JACK“*

No 27 (December 2008)

*Schauer, Carola: "Größe und Ausrichtung der Disziplin Wirtschaftsinformatik an Universitäten im deutschsprachigen Raum - Aktueller Status und Entwicklung seit 1992"*

No 26 (September 2008)

*Milen, Tilev; Bruno Müller-Clostermann: " CapSys: A Tool for Macroscopic Capacity Planning"*

No 25 (August 2008)

*Eicker, Stefan; Spies, Thorsten; Tschersich, Markus: "Einsatz von Multi-Touch beim Softwaredesign am Beispiel der CRC Card-Methode"*

No 24 (August 2008)

*Frank, Ulrich: "The MEMO Meta Modelling Language (MML) and Language Architecture – Revised Version"*



No 23 (January 2008)

*Sprenger, Jonas; Jung, Jürgen: "Enterprise Modelling in the Context of Manufacturing – Outline of an Approach Supporting Production Planning"*

No 22 (January 2008)

*Heymans, Patrick; Kang, Kyo-Chul; Metzger, Andreas, Pohl, Klaus (Eds.): "Second International Workshop on Variability Modelling of Software-intensive Systems"*

## **2007**

No 21 (September 2007)

*Eicker, Stefan; Annett Nagel; Peter M. Schuler: "Flexibilität im Geschäftsprozess-management-Kreislauf"*

No 20 (August 2007)

*Blau, Holger; Eicker, Stefan; Spies, Thorsten: "Reifegradüberwachung von Software"*

No 19 (June 2007)

*Schauer, Carola: "Relevance and Success of IS Teaching and Research: An Analysis of the 'Relevance Debate'"*

No 18 (May 2007)

*Schauer, Carola: "Rekonstruktion der historischen Entwicklung der Wirtschaftsinformatik: Schritte der Institutionalisierung, Diskussion zum Status, Rahmenempfehlungen für die Lehre"*

No 17 (May 2007)

*Schauer, Carola; Schmeing, Tobias: "Development of IS Teaching in North-America: An Analysis of Model Curricula"*

No 16 (May 2007)

*Müller-Clostermann, Bruno; Tilev, Milen: "Using G/G/m-Models for Multi-Server and Mainframe Capacity Planning"*

No 15 (April 2007)

*Heise, David; Schauer, Carola; Strecker, Stefan: "Informationsquellen für IT-Professionals – Analyse und Bewertung der Fachpresse aus Sicht der Wirtschaftsinformatik"*

No 14 (March 2007)

*Eicker, Stefan; Hegmanns, Christian; Malich, Stefan: "Auswahl von Bewertungsmethoden für Softwarearchitekturen"*

No 13 (February 2007)

*Eicker, Stefan; Spies, Thorsten; Kahl, Christian: "Softwarevisualisierung im Kontext serviceorientierter Architekturen"*

No 12 (February 2007)

*Brenner, Freimut: "Cumulative Measures of Absorbing Joint Markov Chains and an Application to Markovian Process Algebras"*

No 11 (February 2007)

*Kirchner, Lutz: "Entwurf einer Modellierungssprache zur Unterstützung der Aufgaben des IT-Managements – Grundlagen, Anforderungen und Metamodell"*

No 10 (February 2007)

*Schauer, Carola; Strecker, Stefan: "Vergleichende Literaturstudie aktueller einführender Lehrbücher der Wirtschaftsinformatik: Bezugsrahmen und Auswertung"*

No 9 (February 2007)

*Strecker, Stefan; Kuckertz, Andreas; Pawlowski, Jan M.: "Überlegungen zur Qualifizierung des wissenschaftlichen Nachwuchses: Ein Diskussionsbeitrag zur (kumulativen) Habilitation"*

No 8 (February 2007)

*Frank, Ulrich; Strecker, Stefan; Koch, Stefan: "Open Model - Ein Vorschlag für ein Forschungsprogramm der Wirtschaftsinformatik (Langfassung)"*

## **2006**

No 7 (December 2006)

*Frank, Ulrich: "Towards a Pluralistic Conception of Research Methods in Information Systems Research"*

No 6 (April 2006)

*Frank, Ulrich: "Evaluation von Forschung und Lehre an Universitäten – Ein Diskussionsbeitrag"*

No 5 (April 2006)

*Jung, Jürgen: "Supply Chains in the Context of Resource Modelling"*

No 4 (February 2006)

*Lange, Carola: "Development and status of the Information Systems / Wirtschaftsinformatik discipline: An interpretive evaluation of interviews with renowned researchers, Part III – Results Wirtschaftsinformatik Discipline"*

## **2005**

No 3 (December 2005)

*Lange, Carola: "Development and status of the Information Systems / Wirtschaftsinformatik discipline: An interpretive evaluation of interviews with renowned researchers, Part II – Results Information Systems Discipline"*

No 2 (December 2005)

*Lange, Carola: "Development and status of the Information Systems / Wirtschaftsinformatik discipline: An interpretive evaluation of interviews with renowned researchers, Part I – Research Objectives and Method"*

No 1 (August 2005)

*Lange, Carola: „Ein Bezugsrahmen zur Beschreibung von Forschungsgegenständen und -methoden in Wirtschaftsinformatik und Information Systems“*





Research Group	Core Research Topics
<b>Prof. Dr. H. H. Adelsberger</b> Information Systems for Production and Operations Management	E-Learning, Knowledge Management, Skill-Management, Simulation, Artificial Intelligence
<b>Prof. Dr. F. Ahlemann</b> Information Systems and Strategic Management	Strategic planning of IS, Enterprise Architecture Management, IT Vendor Management, Project Portfolio Management, IT Governance, Strategic IT Benchmarking
<b>Prof. Dr. P. Chamoni</b> MIS and Management Science / Operations Research	Information Systems and Operations Research, Business Intelligence, Data Warehousing
<b>Prof. Dr. K. Echte</b> Dependability of Computing Systems	Dependability of Computing Systems
<b>Prof. Dr. S. Eicker</b> Information Systems and Software Engineering	Process Models, Software-Architectures
<b>Prof. Dr. U. Frank</b> Information Systems and Enterprise Modelling	Enterprise Modelling, Enterprise Application Integration, IT Management, Knowledge Management
<b>Prof. Dr. M. Goedicke</b> Specification of Software Systems	Distributed Systems, Software Components, CSCW
<b>Prof. Dr. V. Gruhn</b> Software Engineering	Design of Software Processes, Software Architecture, Usability, Mobile Applications, Component-based and Generative Software Development
<b>PD Dr. C. Klüver</b> Computer Based Analysis of Social Complexity	Soft Computing, Modeling of Social, Cognitive, and Economic Processes, Development of Algorithms
<b>Prof. Dr. T. Kollmann</b> E-Business and E-Entrepreneurship	E-Business and Information Management, E-Entrepreneurship/E-Venture, Virtual Marketplaces and Mobile Commerce, Online-Marketing
<b>Prof. Dr. K. Pohl</b> Software Systems Engineering	Requirements Engineering, Software Quality Assurance, Software-Architectures, Evaluation of COTS/Open Source-Components
<b>Prof. Dr. Ing. E. Rathgeb</b> Computer Network Technology	Computer Network Technology
<b>Prof. Dr. R. Unland</b> Data Management Systems and Knowledge Representation	Data Management, Artificial Intelligence, Software Engineering, Internet Based Teaching
<b>Prof. Dr. S. Zelewski</b> Institute of Production and Industrial Information Management	Industrial Business Processes, Innovation Management, Information Management, Economic Analyses